

# Culligan®

**Culligan®  
High  
Efficiency  
Automatic  
Water  
Softener  
Owners  
Guide**





## Attention Culligan Customer

The installation, service and maintenance of this equipment should be rendered by a qualified and trained service technician. Your local independently operated Culligan dealer employs trained service and maintenance personnel who are experienced in the installation, function and repair of Culligan equipment. This publication is written specifically for these individuals and is intended for their use.

We encourage Culligan users to learn about Culligan products, but we believe that product knowledge is best obtained by consulting with your Culligan dealer. Untrained individuals who use this manual assume the risk of any resulting property damage or personal injury.



**WARNING!** Electrical shock hazard! Prior to servicing equipment, disconnect power supply to prevent electrical shock.

**NOTE** This system is not intended for use where water is microbiologically unsafe or with water of unknown quality.



**WARNING!** If incorrectly installed, operated or maintained, this product can cause severe injury. Those who install, operate, or maintain this product should be trained in its proper use, warned of its dangers, and should read the entire manual before attempting to install, operate, or maintain this product.



**WARNING!** This device complies with part 15 of the FCC rules subject to the two following conditions: 1) This device may not cause harmful interference, and 2) This device must accept all interference received including interference that may cause undesired operation.

This equipment complies with Part 15 of the FCC rules. Any changes or modifications not expressly approved by the manufacturer could void the user's authority to operate the equipment. Changes or modifications not expressly approved by the party responsible for compliance could void the user's authority to operate the equipment.



**CAUTION!** To reduce the risk of fire, use only No. 26 AWG or larger telecommunications line cord.



**CAUTION!** This product is not to be used by children or persons with reduced physical, sensory or mental capabilities, or lack of experience or knowledge, unless they have been given supervision or instruction.



**CAUTION!** Children should be instructed not to play with this appliance.



**CAUTION!** If the power cord from the transformer to the unit looks or becomes damaged, the cord and transformer should be replaced by a Culligan Service Agent or similarly qualified person in order to avoid a hazard.

Products manufactured and marketed by Culligan International Company (Culligan) and its affiliates are protected by patents issued or pending in the United States and other countries. Culligan reserves the right to change the specifications referred to in this literature at any time, without prior notice. Culligan, Aqua-Sensor, Tripl-Hull, and SoftMinder are trademarks of Culligan International Company or its affiliates.

**Culligan International Company**  
9399 West Higgins Road, Suite 1100  
Rosemont, Illinois 60018  
1-847-430-2800  
[www.culligan.com](http://www.culligan.com)



## Contents

Thank You.....	<a href="#">1</a>
Specifications .....	<a href="#">2</a>
Introduction .....	<a href="#">5</a>
How Your Water Conditioner Works.....	<a href="#">6</a>
The Culligan Process .....	<a href="#">7</a>
Modes of Operation.....	<a href="#">8</a>
Installation.....	<a href="#">10</a>
Programming .....	<a href="#">27</a>
Maintenance .....	<a href="#">40</a>
Sanitizing Procedure .....	<a href="#">43</a>
Things to Check Before You Call for Service .....	<a href="#">44</a>
Error Codes.....	<a href="#">45</a>
When and How to Bypass Your Water Conditioner .....	<a href="#">47</a>
Performance Data Sheet	
Culligan High Efficiency 9" Water Softener with Soft-Minder® Meter .....	<a href="#">48</a>
Culligan High Efficiency 9" Water Softener with Aqua-Sensor® Sensing Device .....	<a href="#">49</a>
Culligan High Efficiency 10" Water Softener with Soft-Minder® Meter .....	<a href="#">50</a>
Culligan High Efficiency 10" Water Softener with Aqua-Sensor® Sensing Device .....	<a href="#">51</a>
Culligan High Efficiency 12" Water Softener with Soft-Minder® Meter .....	<a href="#">52</a>
Culligan High Efficiency 12" Water Softener with Aqua-Sensor® Sensing Device .....	<a href="#">53</a>
Culligan High Efficiency 14" Water Softener with Soft-Minder® Meter .....	<a href="#">54</a>
Culligan High Efficiency 14" Water Softener with Aqua-Sensor® Sensing Device .....	<a href="#">55</a>
Culligan High Efficiency 9" Upflow Water Softener with Soft-Minder® Meter .....	<a href="#">56</a>
Culligan High Efficiency 9" Upflow Water Softener with Aqua-Sensor® Sensing Device .....	<a href="#">57</a>
Culligan High Efficiency 10" Upflow Water Softener with Soft-Minder® Meter .....	<a href="#">58</a>
Culligan High Efficiency 10" Upflow Water Softener with Aqua-Sensor® Sensing Device .....	<a href="#">59</a>
Culligan High Efficiency Municipal 9" Water Softener .....	<a href="#">60</a>
Culligan High Efficiency Municipal 10" Water Softener .....	<a href="#">61</a>
Culligan High Efficiency Municipal 12" Water Softener .....	<a href="#">62</a>
Culligan High Efficiency Municipal 14" Water Softener .....	<a href="#">63</a>
California Department of Public Health Certificate .....	<a href="#">64</a>
Important Data on Your Water Softener .....	<a href="#">68</a>
Electrical Schematic.....	<a href="#">69</a>
Parts List.....	<a href="#">70</a>
Culligan Limited Warranty .....	<a href="#">77</a>
Index.....	<a href="#">79</a>



## About this Manual

This manual:

- familiarizes the operator with the equipment
- explains installation and setup procedures
- provides basic programming information
- explains the various modes of operation
- gives specifications and troubleshooting information

### Read this Manual First

Before you operate the Culligan High Efficiency Automatic Water Softener, read this manual to become familiar with the device and its capabilities.

### Safe Practices

Throughout this manual there are paragraphs set off by special headings.

Notice (or Note) is used to emphasize installation, operation or maintenance information which is important, but does not present any hazard. For example,

**NOTICE** The nipple must extend no more than 1 inch above the cover plate.

Caution is used when failure to follow directions could result in damage to equipment or property.



**CAUTION!** Disassembly while under water pressure can result in flooding.

Warning is used to indicate a hazard which could cause injury or death if ignored.



**WARNING!** Electrical shock hazard! Unplug the unit before removing the timer mechanism or cover plates!

The CAUTION and WARNING paragraphs are not meant to cover all possible conditions and situations that may occur. Understand that common sense, caution, and careful attention are conditions which cannot be built into the equipment. These MUST be supplied by the personnel installing, operating, or maintaining the system.

Be sure to check and follow the applicable plumbing codes and ordinances when installing this equipment. Local codes may prohibit the discharge of sanitizing or descaling solutions to drain.

Use protective clothing and proper face or eye protection equipment when handling chemicals or tools.

**NOTE** The Culligan High Efficiency Softener is not intended for use with water that is microbiologically unsafe or of unknown quality without adequate disinfection either before or after the system.

**NOTE** Check with your public works department for applicable local plumbing and sanitation codes. Follow local codes if they differ from the standards used in this manual. To ensure proper and efficient operation of the Culligan High Efficiency Filter to your full satisfaction, carefully follow the instructions in this manual.



**Thank You**

## Welcome To Your New World of Better Living with Culligan Water.

The Culligan HE Water Softeners with Soft-Minder® Meter and Aqua-Sensor® sensing device are tested and certified by WQA against NSF/ANSI Standard 372, CSA B483.1, and NSF/ANSI Standard 44 for the effective reduction of hardness (calcium and magnesium), barium, and radium 226/228, as verified and substantiated by test data.



**C USA**

The Culligan HE Municipal Water Softeners are tested and certified by WQA against NSF/ANSI Standard 372, CSA B483.1, and NSF/ANSI Standard 44 for the effective reduction of hardness (calcium and magnesium), and NSF/ANSI Standard 42 for the effective reduction of Chlorine Taste and Odor, as verified and substantiated by test data.

The Culligan HE Water Softener Outdoor Controller Enclosure complies with the UL 50/50E and UL 746C standards for a NEMA 3R Enclosure Rating.

***For installations in Massachusetts, Massachusetts Plumbing Code 248 CMR shall be adhered to. Consult your licensed plumber for installation of this system. This system and its installation must comply with state and local regulations. The use of saddle valves is not permitted.***

If this is your first experience having soft, conditioned water in your home, you'll be amazed at the marvelous difference it makes. We promise that you'll never want to be without it again.

Congratulations, too, on selecting one of the "first family" of water conditioners in the prestigious Culligan High Efficiency Water Softeners. With Culligan's many years of knowledge and experience in water treatment, you can be confident that the model you selected has been designed and engineered to provide years of service with a minimum of care and attention.

Some localities have corrosive water. A water softener cannot correct this problem and so its printed warranty disclaims liability for corrosion of plumbing lines, fixtures or appliances. If you suspect corrosion, your Culligan Dealer has equipment to control the problem.

**NOTICE Sodium Information: Water softeners using sodium chloride for regeneration add sodium to the water. Persons who are on sodium restricted diets should consider the added sodium as part of their overall sodium intake.**

### Serial Numbers

The control valve serial number is located on the back of the timer case.

The media tank serial number is located on the top surface of the tank.

**NOTE DO NOT remove or destroy the serial number. It must be referenced on request for warranty repair or replacement.**



## Specifications

### Culligan High Efficiency Water Conditioners with Aqua-Sensor® Device or Soft-Minder® Meter—Downflow Regeneration

Model	9" Model	10" Model	12" Model	14" Model
Control Valve	1" Reinforced Thermoplastic w/ HE Circuit Boards			
Overall Conditioner Ht	56 in	62 in	60 in	73 in
Media Tank Design	Quadra-Hull™			
Media Tank Dimensions (Dia x Ht)	9 x 48 in	10 x 54 in	12 x 52 in	14 x 65 in
Salt Storage Tank Dimensions (Dia x Ht)	16 x 43 in or 18 x 43 in	16 x 43 in or 18 x 43 in	18 x 43 in	24 x 42 in
Exchange Media, Type and Quantity	Cullex® Media, 1.0 ft³	Cullex Media, 1.5 ft³	Cullex Media, 2.0 ft³	Cullex Media, 3.0 ft³
Underbedding, Type and Quantity	Cullsan® Underbedding, 12 lb	Cullsan Underbedding, 15 lb	Cullsan Underbedding, 20 lb	Cullsan Underbedding, 25 lb
Exchange Capacity @ Salt Dosage Per Recharge	17,854 gr @ 4.0 lb	26,781 gr @ 6.0 lb	31,352 gr @ 7.0 lb	51,726 gr @ 12 lb
	27,108 gr @ 8.0 lb	40,662 gr @ 12.0 lb	48,458 gr @ 16.0 lb	75,582 gr @ 24 lb
	31,736 gr @ 12.0 lb	47,604 gr @ 18.0 lb	59,267 gr @ 18.0 lb	88,549 gr @ 36 lb
Efficiency rated dosage <sup>1</sup>	4,463 gr/lb @ 4 lb salt dosage	4,463 gr/lb @ 6 lb salt dosage	4,479 gr/lb @ 7 lb salt dosage	4,310 gr/lb @ 12 lb salt dosage
Freeboard to Media <sup>2</sup>	14.5 in	14.5 in	16 in	25 in
Freeboard to Underbedding <sup>3</sup>	44.5 in	47.5 in	46 in	59 in
Salt Storage Capacity	250 lb or 375 lb	250 lb or 375 lb	375 lb	600 lb
Rated Service Flow @ Pressure Drop	9.0 gpm @ 11 psi	9.4 gpm @ 12 psi	10.0 gpm @ 10 psi	10.6 gpm @ 11 psi
Auxiliary Flow Rate <sup>4</sup>	10.8 gpm @ 15 psi	11.0 gpm @ 15 psi	12.6 gpm @ 15 psi	12.8 gpm @ 15 psi
Total Hardness, Maximum	75 gpg	99 gpg	99 gpg	99 gpg
Total Iron, Maximum	5 ppm			
Hardness to Iron Ratio, Minimum	8 gpg to 1 ppm			
Operating Pressure	20-125 psi (138-862 kPa)			
Operating Pressure (Canada)	20-90 psi (138-621 kPa)			
Operating Temperature	33-120°F (0-49°C)			
Electrical Requirements	24V/60 Hz			
Electrical Power Consumption, Min/Max	8.4 watts/21.6 watts			
Drain Flow, Maximum <sup>5</sup>	2.5 gpm	2.5 gpm	3.0 gpm	5.3 gpm
Recharge Time, Average <sup>6</sup> Recharge Water	78 minutes	67 minutes	62 minutes	76 minutes
Consumption, Average <sup>6</sup>	47 gallons	45 gallons	67 gallons	155 gallons

<sup>1</sup>The efficiency rated dosage is only valid at the stated salt dosage and is efficiency rated according to NSF/ANSI Standard 44.

<sup>2</sup>Measured from top of media to top surface of tank threads (backwashed and drained).

<sup>3</sup>Measured from top of underbedding to top surface of tank threads.

<sup>4</sup>Auxiliary flow rates do not represent the maximum service flow rate used for determining the softener's rated capacity and efficiency and that continuous operation at these flow rates greater than the maximum service flow rate may affect capacity and efficiency performances.

<sup>5</sup>Backwash at 120 psi.

<sup>6</sup>10 minute backwash, 4 lb. 9" model, 6 lb. 10" model, 7 lb. 12" model, or 12 lb. 14" model salt dosage.



## Culligan High Efficiency Softener—Upflow Regeneration

Model	9" Model	10" Model
Control Valve	1" Reinforced Thermoplastic with HE Circuit Board	
Overall Conditioner Height	56 in	62 in
Media Tank Design	Quadra-Hull™	
Media Tank Dimensions (Dia x Ht)	9 x 48 in	10 x 54 in
Salt Storage Tank Dimensions (Dia x Ht)	16" x 43" or 18" x 43"	
Exchange Media, Type and Quantity	Cullex® Media, 1.0 ft³	Cullex Media, 1.5 ft³
Underbedding, Type and Quantity	Cullsán® Underbedding, 12 lb	Cullsán Underbedding, 15 lb
Exchange Capacity @ Salt Dosage Per Recharge	9,792 gr @ 2.0 lb	30,081 gr @ 6.0 lb
	17,366 gr @ 4.0 lb	47,726 gr @ 12.0 lb
	27,306 gr @ 8.0 lb	54,975 gr @ 18.0 lb
Efficiency rated dosage <sup>1</sup>	4,896 gr/lb @ 2 lb salt dosage	5,014 gr/lb @ 6 lb salt dosage
Proportional Brining Efficiency Rating <sup>2</sup>	5,760 gr/lb @ 2 lb salt dosage	5,898 gr/lb @ 6 lb salt dosage
Freeboard to Media <sup>3</sup>	14.5 in	14.5 in
Freeboard to Underbedding <sup>4</sup>	44.5 in	47.5 in
Salt Storage Capacity	250 lb or 375 lb	
Rated Service Flow @ Pressure Drop	9.0 gpm @ 11 psi	9.4 gpm @ 12 psi
Auxiliary Flow Rate <sup>5</sup>	10.8 gpm @ 15 psi	11.0 gpm @ 15 psi
Total Hardness, Maximum	30 gpg	
Total Iron, Maximum	2 ppm	
Hardness to Iron Ratio, minimum	8 gpg to 1 ppm	
Operating Pressure	20-125 psi (138–862 kPa)	
Operating Pressure (Canada)	20-90 psi (138–621 kPa)	
Operating Temperature	33-120°F (0–49°C)	
Electrical Requirements	24V/60 Hz	
Electrical Power Consumption, Min/Max	8.4 watts/21.6 watts	
Drain Flow, Maximum <sup>6</sup>	2.2 gpm	2.3 gpm
Recharge Time, Average <sup>7</sup> Recharge Water	68 minutes	57 minutes
Consumption, Average <sup>7</sup> (Evaluated by WQA)	33 gallons	35 gallons
Consumption, Average <sup>8</sup> (Not evaluated by WQA)	25.5 gallons	27.5 gallons

<sup>1</sup>The efficiency rated dosage is only valid at the stated salt dosage and 5-minute backwash. It is efficiency rated according to NSF/ANSI 44.

<sup>2</sup>The Proportional Brining Efficiency Rating assumes a 20 percent reserve capacity at the time of regeneration that is typical of what the manufacturer expects under real-world operation. Proportional brining is not measured by NSF/ANSI 44, and so this claim is not, and can not, be rated to NSF/ANSI 44.

<sup>3</sup>Measured from top of media to top surface of tank threads. (backwashed and drained).

<sup>4</sup>Measured from top of underbedding to top surface of tank threads.

<sup>5</sup>Auxiliary flow rates do not represent the maximum service flow rate used for determining the softener's rated capacity and efficiency and that continuous operation at these flow rates greater than the maximum service flow rate may affect capacity and efficiency performances.

<sup>6</sup>Backwash at 35 psi (830 kPa).

<sup>7</sup>5 minute backwash, 2 lb. 9" model, 6 lb. 10" model. These values have been tested and certified by WQA.

<sup>8</sup>2 minute backwash, 2 lb. 9" model, 6 lb. 10" model. These values are based on the manufacturer recommended backwash time.



## Culligan HE Municipal Water Softener

	9" Model	10" Model	12" Model	14" Model
Control Valve	1", 5-cycle Reinforced Thermoplastic with Global Electronic (GBE) Circuit Board			
Overall Conditioner Height	54 in	60 in	58 in	71 in
Media Tank Design	Quadra-Hull™			
Media Tank Dimensions (Dia x Ht)	9 x 48 in	10 x 54 in	12 x 52 in	14 x 65 in
Salt Storage Tank Dimensions (Dia x Ht)	16 x 43 in or 18 x 43 in	16 x 43 in or 18 x 43 in	18 x 43 in	24 x 42 in
Exchange Media, Type and Quantity	Cullex® Media, 0.8 ft <sup>3</sup>	Cullex® Media, 1.0 ft <sup>3</sup>	Cullex® Media, 1.5 ft <sup>3</sup>	Cullex® Media, 2.3 ft <sup>3</sup>
Carbon Media, Quantity	6 lbs	8 lbs	12 lbs	18 lbs
Underbedding, Type and Quantity	Cullsans® Underbedding, 12 lb	Cullsans® Underbedding, 15 lb	Cullsans® Underbedding, 20 lb	Cullsans® Underbedding, 25 lb
Exchange Capacity @ Salt Dosage Per Recharge	17,119 gr @ 4.0 lb	21,399 gr @ 5.0 lb	29,062 gr @ 7.0 lb	39,118 gr @ 9.0 lb
	25,232 gr @ 8.0 lb	31,540 gr @ 10.0 lb	43,990 gr @ 18.0 lb	59,297 gr @ 18.0 lb
	27,806 gr @ 12.0 lb	34,758 gr @ 15.0 lb	49,343 gr @ 30.0 lb	71,448 gr @ 28.0 lb
Efficiency rated dosage <sup>1</sup>	4,280 gr/lb @ 4 lb salt dosage	4,280 gr/lb @ 5 lb salt dosage	4,152 gr/lb @ 7 lb salt dosage	4,346 gr/lb @ 9 lb salt dosage
Chlorine Taste and Odor Capacity	300,000 gallons	339,000 gallons	621,000 gallons	935,000 gallons
Freeboard to Media <sup>2</sup>	15.75 in	19.5 in	17.31 in	25.89 in
Freeboard to Underbedding <sup>3</sup>	44.5 in	47.5 in	46 in	59 in
Salt Storage Capacity	250 lb or 375 lb		375 lb	650 lb
Rated Service Flow @ Pressure Drop	9.0 gpm @ 12 psi	9.4 gpm @ 11 psi	10.0 gpm @ 11 psi	10.6 gpm @ 11 psi
Total Hardness, Maximum	15 gpg			
Total Iron, Maximum	0 ppm			
Color	Less Than 1			
Turbidity	Less Than 5 NTU			
TOC	Less Than 0.5 PPM			
Operating Pressure	20-125 psi (138-862 kPa)			
Operating Pressure (Canada)	20-90 psi (138-621 kPa)			
Operating Temperature	33-120°F (0-49°C)			
Electrical Requirements	24V/60 Hz			
Electrical Power Consumption, Min/Max	8.4 Watts/21.6 Watts			
Drain Flow, Maximum <sup>4</sup>	2.6 gpm	2.6 gpm	3.2 gpm	6.2 gpm
Recharge Time, Average <sup>5</sup> Recharge Water	78 min	67 min	62 min	76 min
Consumption, Average <sup>5</sup>	70 gal	70 gal	97 gal	162 gal

<sup>1</sup>The efficiency rated dosage is only valid at the stated salt dosage and is efficiency rated according to NSF/ANSI 44.

<sup>2</sup>Measured from top of media to top surface of tank threads. (backwashed and drained).

<sup>3</sup>Measured from top of underbedding to top surface of tank threads.

<sup>4</sup>Backwash at 120 psi (830 kPa).

<sup>5</sup>10 minute backwash, 4 lb. 9" model, 5 lb. 10" model, 7 lb. 12" model, or 9 lb. 14" model.





## Introduction

### **It's All So Easy, So Economical, So Efficient, So Enjoyable!**

#### **Kind To Skin And Complexion**

Soft water will help prevent red, itchy or dry skin because there are no hardness impurities to cause soreness, no soap curd to coat the skin. Shaving is easier, smoother—either with a blade or electric shaver.

#### **Bathing And Showering**

You'll use far less soap with conditioned water. Use your soap very sparingly—not as you did before soft water. Just a quick rinse removes all lather, leaving your skin pleasantly smooth and silky because now it's free of sticky soap curd and film.

#### **Saves Washing Costs. Helps Control Environmental Pollution**

Soft water washes whiter and cleaner with less soap or detergent. Because the hardness impurities are removed, your soap can concentrate solely on washing. People usually find that they can reduce the amount of soap they use substantially. If you normally use a cup per wash load with hard water, try using 1/3 cup depending on the size of your wash load and the degree of soil. Different amounts are required, but you can use less with softened water. An added bonus is the fact that your washable fabrics will last longer.

#### **Super Hair Conditioning**

Soft water is great for scalp and hair care. No insoluble deposits are formed. Hair is shinier, softer, more manageable. Reduce the amount of shampoo you have normally used.

#### **Dishes Are A Delight**

Washed by hand or in a dishwasher, glassware, dishes and silver wash cleaner, easier. Follow your dishwasher manufacturer's instructions. Soft water promotes sanitation because no greasy hard water film can form to collect or harbor bacteria.

#### **Easier Housekeeping, Gleaming Fixtures**

You'll be amazed at the marvelous difference. Just a swish of the cloth, and the bathtub or shower and fixtures are clean and sparkling. Imagine, no scouring! No hard water scum to cause rings, streaks, spots and stains. To keep their gleaming luster, simply wipe fixtures with a towel after use. Formica, tile, walls, floors, woodwork surfaces clean easier, stay clean longer. You'll save on cleaning aids and save on time.

#### **Saves Water-Heating Energy, Helps Water-Using Appliances**

Soft water reduces the formation of rock-like hard water scale that encrusts water heaters, hot water pipes, shower heads, and water-using appliances. This scale can cause premature maintenance and failure.

Elimination of hard water also provides substantial energy savings because scale acts as an insulator, wasting electricity or gas used to heat water.

#### **Water For Lawns And Household Plants**

If possible, lawn sprinkling faucets should be supplied with hard water primarily because it is uneconomical to soften so much water.

Household plants are much more sensitive than lawns with respect to the kind of water which is best. First, because they receive no rainfall and, second, there is little or no drainage of the soil. Preferably they should be watered with rainwater or water which is low in mineral content such as distilled or demineralized water. Softened water is not recommended for house plants because a build-up of sodium in the soil may interfere with efficient absorption of water by the plant root system. Additional information may be obtained from your independently operated Culligan dealer.

#### **Culligan Municipal Softener**

With the Culligan Municipal softener you will experience the above benefits in addition to the reduction of chlorine taste and odor for a fresh, clean taste and smell.



## How Your Water Conditioner Works

### Why Water Gets Hard And How It Is Softened

All of the fresh water in the world originally falls as rain, snow, or sleet. Surface water is drawn upward by the sun, forming clouds. Then, nearly pure and soft as it starts to fall, it begins to collect impurities as it passes through smog and dust-laden atmosphere. And as it seeps through soil and rocks it gathers hardness, rust, acid, unpleasant tastes and odors.

Water hardness is caused primarily by limestone dissolved from the earth by rainwater. Because of this, in earlier times people who wanted soft water collected rainwater from roofs in rain barrels and cisterns before it picked up hardness from the earth.

Some localities have corrosive water. A softener cannot correct this problem and so its printed warranty disclaims liability for corrosion of plumbing lines, fixtures or appliances. If you suspect corrosion, your Culligan Man has equipment to control the problem.

Iron is a common water problem. The chemical/physical nature of iron found in natural water supplies is exhibited in four general types:

1. **Dissolved Iron**—Also called ferrous or “clear water” iron. This type of iron can be removed from the water by the same ion exchange principle that removes the hardness elements, calcium and magnesium. Dissolved iron is soluble in water and is detected by taking a sample of the water to be treated in a clear glass. The water in the glass is initially clear, but on standing exposed to the air, it may gradually turn cloudy or colored as it oxidizes.
2. **Particulate Iron**—Also called ferric or colloidal iron. This type of iron is an undissolved particle of iron. A softener will remove larger particles, but they may not be washed out in regeneration effectively and will eventually foul the ion exchange resin. A filtering treatment will be required to remove this type of iron.
3. **Organic Bound Iron**—This type of iron is strongly attached to an organic compound in the water. The ion exchange process alone cannot break this attachment and the softener will not remove this type of iron.
4. **Bacterial Iron**—This type of iron is protected inside a bacteria cell. Like the organic bound iron, it is not removed by a water softener.

When using a softener to remove both hardness and dissolved iron it is important that it regenerates more frequently than ordinarily would be calculated for hardness removal alone. Although many factors and formulas have been used to determine this frequency, it is recommended that the softener be regenerated when it has reached 50–75% of the calculated hardness alone capacity. This will minimize the potential for bed fouling. (Iron removal claims have not been verified by the Water Quality Association.)

If you are operating a water softener on clear water iron, regular resin bed cleaning is needed to keep the bed from coating with iron. Even when operating a softener on water with less than the maximum of dissolved iron, regular cleanings should be performed. Clean every six months or more often if iron appears in your conditioned water supply. Use resin bed cleaning compounds carefully following the directions on the container.



**CAUTION! Do not use where the water is microbiologically unsafe or with water of unknown quality without adequate disinfection before or after the unit.**



Your Culligan water conditioner consists of three basic components, (A) the Control Valve, (B) the Mineral Tank, and (C) the Brine System.

### A. Control Valve

The exclusive Culligan control valve automatically performs a variety of tasks that are necessary for the proper operation of your water conditioner. These tasks, commonly referred to as cycles or operating positions, are **Service**, **Regeneration**, and **Brine Refill**.

1. **Service:** While the control valve is in the service cycle, hard water is directed down through the column of Cullex® resin where hardness minerals are removed from the water. The softened water is then directed into your household plumbing lines. The ability of the Cullex resin to remove hardness minerals needs to be periodically replenished; this is referred to as ...
2. **Regeneration:** While the control valve is in the regeneration cycle, water is first directed up through the column of Cullex resin to flush accumulated sediment out of the resin and down the drain. Then, the regenerant brine solution is slowly drawn from the bottom of the salt storage tank of the Brine System and is directed down through the column of Cullex resin, restoring the ability of the resin to remove hardness minerals from your water supply. Once completed, the regeneration cycle is followed by ...
3. **Brine Refill:** While the control valve is in the brine refill cycle, a predetermined amount of water is directed to the salt storage tank of the Brine System so that additional salt can be dissolved to provide the brine solution that will be needed for the next regeneration cycle.



### B. The Mineral Tank

The Mineral Tank contains the Cullex resin column, Cullsant® underbedding, and an outlet manifold (the Culligan Municipal also includes carbon media for chlorine taste & odor reduction). The number of gallons of hard water that can be softened by the Cullex resin column before it needs regeneration is called the "capacity" of the resin column, and depends upon the amount of hardness minerals in each gallon of water (expressed as grains per gallon) and upon the amount of regenerant brine solution (expressed as pounds of salt) passed through the resin column during regeneration.

Your Culligan service person, taking into account the hardness of your water and the amount of softened water your household may reasonably expect to use each day, has carefully established how often the softener will regenerate and how much salt will be used for each regeneration. This will ensure that all of your soft water needs will be fulfilled without using an excessive amount of salt.

### C. The Brine System

The Brine System consists of a salt storage container and hydraulic Dubl-Safe™ valve. The salt storage container holds the salt that is used to make the regenerant brine solution. The hydraulic Dubl-Safe valve limits the amount of water that is returned to the salt storage tank during the brine refill cycle.

Because a predetermined amount of salt is dissolved with each brine refill cycle, the salt must be periodically replenished in order to maintain efficient operation. Your Culligan service person will be able to tell you about how often salt must be added to the salt storage container.

## The Culligan Process



## Modes of Operation

### Water Meter Mode

In water meter mode, the controller keeps track of the quantity of water that has flowed through the resin bed. Based on the influent water hardness and the hardness capacity of the resin bed, a service life expectancy in the quantity of softened water is calculated and programmed into the control. When the set point is reached, regeneration is triggered. If the predict mode is not selected the regeneration will start at time of regeneration. In immediate mode the regeneration starts as soon as the regeneration signal is provided. If time clock backup is set and the capacity has not been exhausted but the days since last regen is greater than time clock backup, setting the softener will immediately regenerate.

### Aqua-Sensor® Mode

The Aqua-Sensor is a conductivity probe that senses when the hardness front passes through the resin bed. It functions independently of the influent water hardness so therefore, is useful in conditions when the influent water hardness varies throughout the year. It provides for the most efficient mode of operation. In addition to sensing when a resin bed is exhausted, it can also be used to determine when the brine solution is rinsed from the resin bed during the Brine Draw/Slow Rinse cycle triggering the control to move to fast rinse. This patented feature provides water savings by optimizing the amount of rinse water required to completely rinse out the resin bed.

### Smart Brine Tank Probe

The smart brine tank probe monitors conditions inside the brine tank. It predicts when salt needs to be added to the brine tank, detects the presence of salt-bridging, eductor line plugging and brine tank overflowing.

### Wireless Remote Control

The wireless remote control displays the current status of the water softener or filters and allows for remote control. It can be located up to 200 feet away from the softener (depending upon building construction materials). The wireless remote displays information about softener performance, problems, days of salt remaining and allows remote control for regeneration.

The wireless remote control is designed to communicate at 915 MHz and to work without interference with other 915 MHz devices such as cordless telephones and baby monitors.

### Modem

The modem allows for the system to be remotely monitored detecting problems before they occur, to schedule salt delivery when it is needed and to keep the system software up to date with the latest advances.

### Manual Regeneration

Manual regeneration can be initiated via the softener control valve or wireless remote display. Manual regeneration can be initiated to begin regeneration immediately or that night. To immediately initiate regeneration, press and hold  for at least ten (10) seconds. To cancel a delayed regeneration, press and hold  for at least five (5) seconds.

### Predict Mode

The Predict Mode is used with the flow meter to determine the optimum regeneration point. Before the regeneration starts, the control will compare the remaining capacity value with the average daily water use. If the average daily water usage is less than the reserve capacity, the controller will wait 24 more hours before regeneration. If the reserve capacity is less than the average daily water usage, the control will initiate regeneration. This works in delay mode only. At any time, if the total capacity value is reached, the control will initiate an immediate regeneration.

### Pre-Rinse Mode

The Pre-rinse mode is used to pre-rinse the softener resin bed or filter media. The pre-rinse in flow meter mode will occur after the control has sensed that no water has flowed through the control for a period of X hours (can be set through the programming menu). When the control is in this mode, once the X amount



of hours have elapsed the control will cycle to the fast rinse position for the pre-set length of minutes and then return to the home or service position.

### **Down Flow Regeneration**

Water and regenerate flow downward through the media tank.

### **Up Flow Regeneration**

Water flow is downward and regenerate flow is upward through the media tank. The significance of this is that regeneration will be most effective in those parts of the resin bed which are treated with the freshest regenerate solution. There will tend to be less hardness leakage with up-flow regeneration.

### **Proportional Brining**

The control monitors your softened water usage making only enough brine to regenerate that part of the resin bed that has been exhausted. In this way the amount of salt used relates directly to the amount of softened water used, making it more efficient and cost effective. Proportional brining can only be used with upflow regeneration. The Aqua-Sensor or meter can be used to initiate a regeneration.

### **Dial-A-Softness®**

Dial-A-Softness is a manual adjustment built into the control valve that allows for variable hardness bypass into the softened water. The hard water bypass can be adjusted from 0% to 30%. The Dial-A-Softness also increases the softener capacity in proportion to the percent hard water bypass (less salt used).



## Installation

**NOTE** Read this section entirely before starting the installation. Follow all applicable plumbing and electrical codes.

### Component Description

The water conditioner is shipped from the factory in a minimum of three cartons. With the exception of media containers, remove all components from their cartons and inspect them before starting installation.

### Control Valve Assembly

Includes the control valve, bypass valve, and meter. Small parts packages will contain additional installation hardware, and the conditioner Owner's Guide.

### Media Tank

Includes Quadra-Hull™ media tank complete with Cullex® ion exchange resin, underbedding and outlet manifold (12" and 14" tanks are shipped without media).

### Salt Storage Tank Assembly

Includes salt storage container with support plate and Dubl-Safe™ brine refill valve and chamber.

### Tools and Materials

The following tools and supplies will be needed, depending on installation method.

**NOTE** Check and comply with your state and local codes. You must follow these guidelines.

**For installations in Massachusetts, Massachusetts Plumbing Code 248 CMR shall be adhered to. Consult your licensed plumber for installation of this system. This system and its installation must comply with state and local regulations. The use of saddle valves is not permitted.**

### All Installations

- Safety glasses
- Phillips screwdrivers, small and medium tip.
- Gauge assembly
- Silicone lubricant (P/N 00471507 or equivalent)—Do Not Use Petroleum-Based Lubricants
- A bucket, preferably light-colored
- Towels

### Special Tools

- Torch, solder and flux for sweat copper connections
- Use only lead-free solder and flux for all sweat-solder connections as required by state and federal codes.
- Threading tools, pipe wrenches and thread sealer for threaded connections.
- Saw, solvent and cement for plastic pipe connections.



## Materials

- Brine line, 3/8" (P/N 01009819 or equivalent)
- Drain line, 1/2" (P/N 00303082, gray, semi-flexible; P/N 00331946, black, semi-rigid; or equivalent)
- Thread sealing tape
- Pressure reducing valve (if pressure exceeds 125 psi [860 kPa])
- Pipe and fittings suited to the type of installation
- Water softener salt (rock, solar or pellet salt formulated specifically for water softeners)

## Application

### Water Quality

Verify that raw water hardness and iron are within limits. Note the hardness for setting the salt dosage and recharge frequency.

Iron is a common water problem. The chemical/physical nature of iron found in natural water supplies is exhibited in four general types: Dissolved Iron, Particulate Iron, Organic Bound Iron and Bacterial Iron. Hardness sample kits are available through your local Culligan dealer.

### Pressure

If pressure exceeds 125 psi (860 kPa), install a pressure reducing valve (see materials checklist). On private water systems, make sure the minimum pressure (the pressure at which the pump starts) is greater than 20 psi (140 kPa). Adjust the pressure switch if necessary.



**CAUTION!** Do not use where the water is microbiologically unsafe or with water of unknown quality adequate disinfection before or after the unit.



**CAUTION!** The use of a pressure reducing valve may limit the flow of water in the household.

### Temperature

Do not install the unit where it might freeze, or next to a water heater or furnace or in direct sunlight. Outdoor installation is not recommended, and voids the warranty. Use the Culligan Outdoor HE softener for outdoor installations. The Culligan Outdoor HE softener has been certified by Underwriter's Laboratories for outdoor installation. If installing in an outside location, you must take the steps necessary to assure the softener installation plumbing, wiring, etc. Areas well protected from the elements (sunlight, rain, wind, heat, cold), contamination, vandalism, etc. as when installed indoors.

### Location

#### Space Requirements

Allow 6–12 inches (15–30 cm) behind the unit for plumbing and drain lines and 4 feet (1.3 meters) above for service access and filling the salt container.

#### Floor Surface

Choose an area with solid, level floor free of bumps or irregularities. Bumps, cracks, stones and other irregularities can cause the salt storage tank bottom to crack when filled with salt and water.



### Drain Facilities

Choose a nearby drain that can handle the rated drain flow (floor drain, sink or stand pipe). Refer to [Table 3 "Height of Discharge Above Floor Level Operating." on page 21](#), for maximum drain line length.

**NOTE** Most codes require an anti-siphon device or air gap. Observe all local plumbing codes and drain restrictions. The system and installation must comply with all state and local laws and regulations.

### Electrical Facilities

A 10-foot cord and wall mount plug-in transformer are provided. The customer should provide a receptacle, preferably one not controlled by a switch that can be turned off accidentally. Observe local electrical codes.

**NOTE** The softener works on 24 Volt/60 Hz electrical power only. Be sure to use the included transformer. Be sure the electrical outlet and transformer are in an inside location to protect from moisture. Properly ground to conform with all governing codes and ordinances. Observe all local plumbing codes and drain restrictions. The system and installation must comply with all state and local laws and regulations.

**NOTE** P/N 01020620 and P/N 01018133 plug-in transformer are rated for indoor installations only.

### Placement

**NOTE** Read this section entirely before starting the installation. Follow all applicable plumbing and electrical codes.

Refer to [Figure 1](#) for system placement.

1. With the exception of media containers, open the remaining containers, remove all the components, and inspect them before starting installation.
2. Set the media tank on a solid, level surface near water, drain and electrical facilities.
3. Set the brine system on a flat, smooth, solid surface as near the media tank as possible.

### Tank Assembly

9" and 10" tanks are filled with media at the factory.

1. Before the unit can be connected to the plumbing, you must insert the manifold and load the media into the tank for 12" and 14" units.



**CAUTION!** Do not lay the tank down unless a suitable lifting device is available. Personal injury and damage to the unit can result if dropped.





## Position the Mineral Tank(s)

Determine the location for the mineral tank(s) prior to loading, because they will be difficult to move after the underbedding and gravel are loaded.

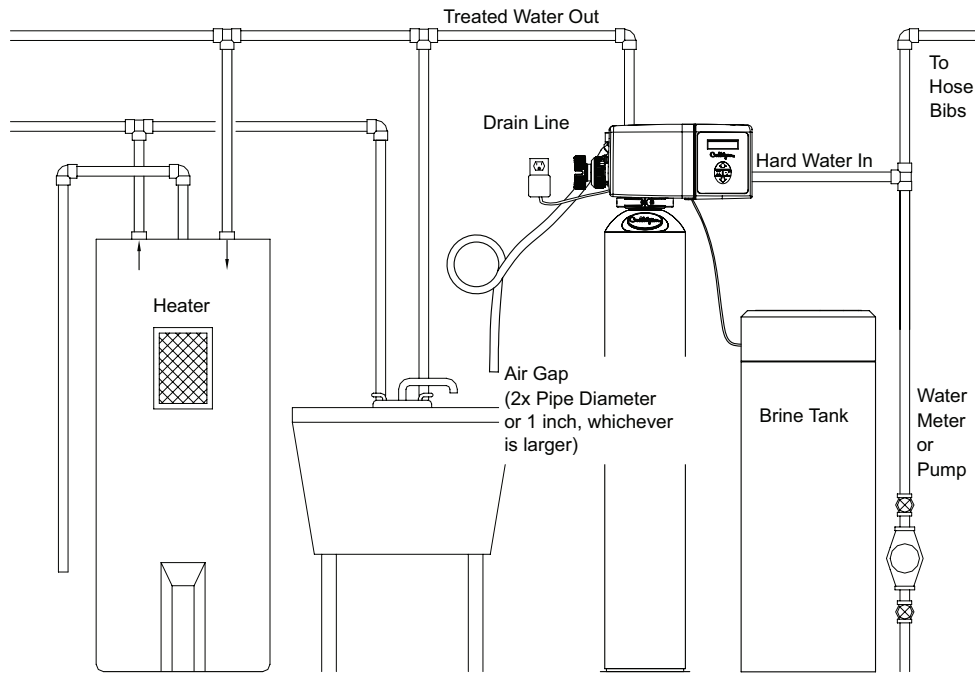

Figure 1. HE system placement.

## Load the Tank (12" and 14" Tanks)

1. Position the tank so that the Culligan® logo is in the front.
2. Remove the inlet strainer.
3. Install the outlet manifold into the tank (Figure 2).
4. Cover the tops of the manifolds with a clean rag.
5. Using a large-mouth funnel, load the Culligan underbedding through the top of the tank.



**CAUTION! DO NOT allow the outlet manifold to move when loading the media. The manifold must remain vertical to ensure a good seal at the gasket. Rap the tank near the bottom with a rubber mallet to level the sand.**

6. Load the tank with the Cullex® ion exchange resin. Leveling is not required.
7. Remove the funnel.
8. Install the inlet strainer making sure to thread the strainer until it bottoms out on the tank thread. Failure to install the strainer correctly can cause the control to leak.

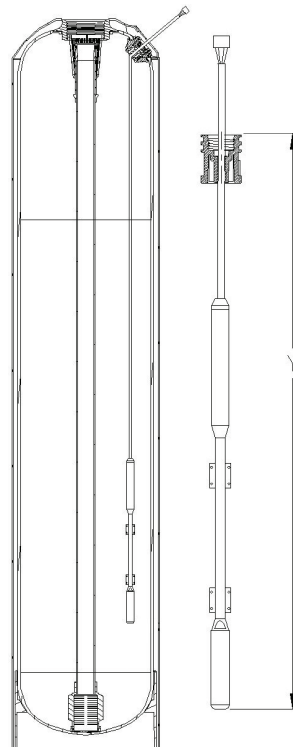

Figure 2. HE Softener tank.



## Install Aqua-Sensor

1. Measure the sensor cable length as shown in dimension Y. See [Figure 2](#) and Table 1 (the Aqua-Sensor cord is set at the factory for a 9" tank).

Tank Model	Dimension Y
9" Quadra-Hull™ Tank	40"
10" Quadra-Hull Tank	44"
12" Quadra-Hull Tank	42"
14" Quadra-Hull Tank	52"

Table 1. HE cable lengths.

2. Loosen the small Aqua-Sensor Plug; a needle-nose pliers works best. See [Figure 3](#).
3. Moisten the cable sheath and slide the cable grip up or down to the proper cable length.
4. Tighten the small Aqua-Sensor plug so that the fitting cannot slide along the cable.

**NOTE** There must be no kinks or bends in the cable.

5. Insert the probe and cable through the Aqua-Sensor port.
6. Tighten the Aqua-Sensor plug into the Aqua-Sensor port.

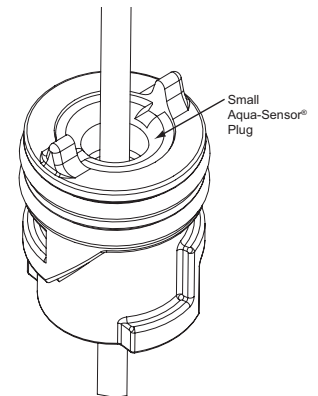

Figure 3. Aqua-Sensor plug.

**NOTE** The media tank must be backwashed so that the Aqua-Sensor probe can fall into the proper position. See ["Recommended Aqua-Sensor® Start-Up Procedure" on page 39](#).



## Mount the Control Valve

See [Figure 4](#) for an illustration on mounting the control valve to the tank.

1. Assemble the O-rings, located in the parts pack, to the tank adapter.
2. The valve adapter O-ring sits on the first step on the adapter. See [Figure 5](#).

**NOTE** Do not push the top O-ring down to the flange surface on the adapter.

**NOTE** The larger of the two O-rings in the parts should be positioned between the adapter and the valve. Do not stretch the smaller O-ring onto the top of the tank adapter.

3. Lubricate only the top o-ring on the tank adapter and the outlet manifold O-ring with silicone lubricant.
4. Screw the adapter into the tank until the adapter bottoms out on the tank flange.

**NOTE** The adapter only needs to be tightened hand-tight to the tank flange.

5. Align the manifold with the center opening in the valve, and firmly press the valve onto the adapter.

**NOTE** Make sure to push the valve straight down onto the manifold. If the valve is cocked, it may cause the O-ring to slip off the manifold.

6. Assemble the tank clamp to the control, and tighten the clamp screw.

**NOTE** The clamp and valve will be able to rotate on the tank until pressure is applied.

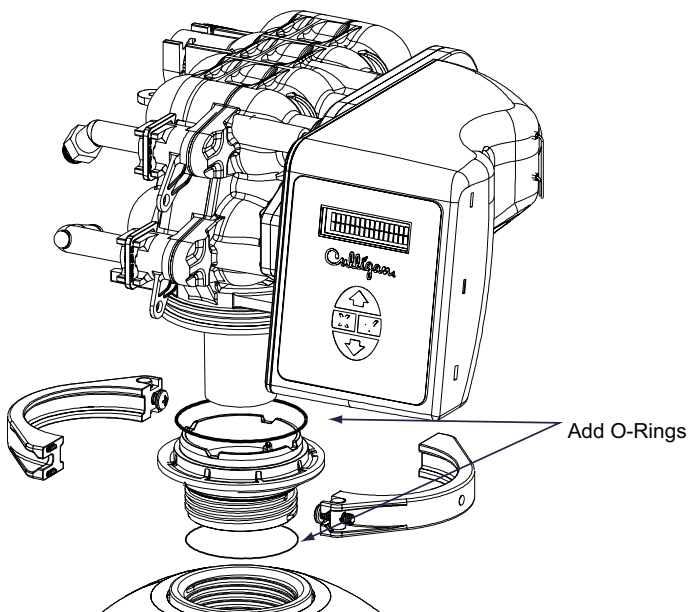

Figure 4. Mounting the control valve.



Figure 5. Valve adapter O-ring.



### Backwash Flow Control, Eductor Nozzle–Throat

Use the recommended backwash flow control, eductor nozzle, and eductor throat for various size tanks. See Table 2.

Refer to Figure 6 through [Figure 9](#) and instructions below for changing the backwash flow control, eductor nozzle, and eductor throat.

Unit	Backwash Flow	Nozzle	Throat	Brine Refill Flow
9" Upflow	2.5–3.1 gpm (#2 Brown)*	Blue*	Gray*	0.45 gpm
10" Upflow	2.5–3.1 gpm (#2 Brown)*	Blue	White	0.45 gpm
9" Downflow	2.5–3.1 gpm (#2 Brown)*	Blue*	Light Brown*	0.45 gpm
10" Downflow	2.5–3.1 gpm (#2 Brown)*	Beige	Light Brown	0.45 gpm
12" Downflow	3.0–3.2 gpm (#3 Green)	Beige	Light Brown	0.8 gpm
14" Downflow	5.3 gpm (Black)	Green	Blue	0.8 gpm

\* Shipped assembled inside the control standard from factory

Table 2. Flow Restrictors.

**NOTE For upflow models, the backwash and fast rinse default times are set at five (5) minutes.**

### Eductor Nozzle and Throat Replacement

Refer to Figure 6 and the instructions below when changing the eductor nozzle and throat.

1. Remove the eductor cap clip.
2. Remove the eductor cap.
3. Remove the eductor assembly.
4. Remove the eductor screen from the assembly.
5. Remove the blue nozzle and replace it with the correct nozzle. See Table 2.
6. Make sure to put the O-ring on the nozzle.
7. Replace the eductor throat if required.
8. Reverse the procedure to reassemble.

**NOTE Observe the orientation of the arrow on the eductor cap. The arrow faces down for downflow regeneration applications; the arrow faces up for upflow/proportional brining regeneration applications.**

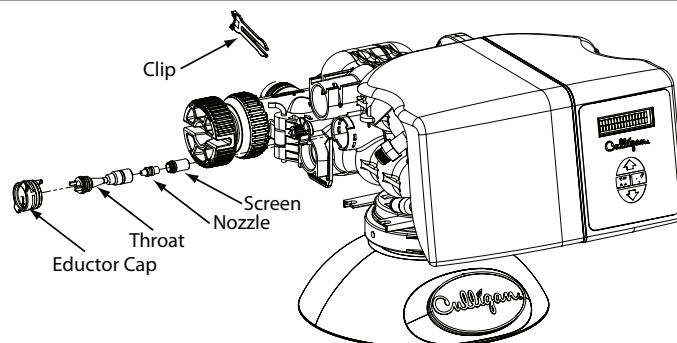

Figure 6. Removing the eductor nozzle and throat.



## Backwash Flow Control Replacement

Refer to Figure 7 through Figure 9, [Table 2](#), and instructions below to replace the backwash flow control.

1. Remove the cover by releasing the cover fastener from the control valve. See Figure 7 and Figure 8.
2. Remove the drain clip and pull the drain elbow straight off. See Figure 9.
3. Remove the backwash flow control located behind the elbow.
4. Install the correct backwash flow control. See [Table 2](#).
5. Reverse the procedure to reassemble.

**NOTE** The number on the flow control should face into the valve body.

**NOTE** Do not re-install the cover until the drain line tubing is connected.

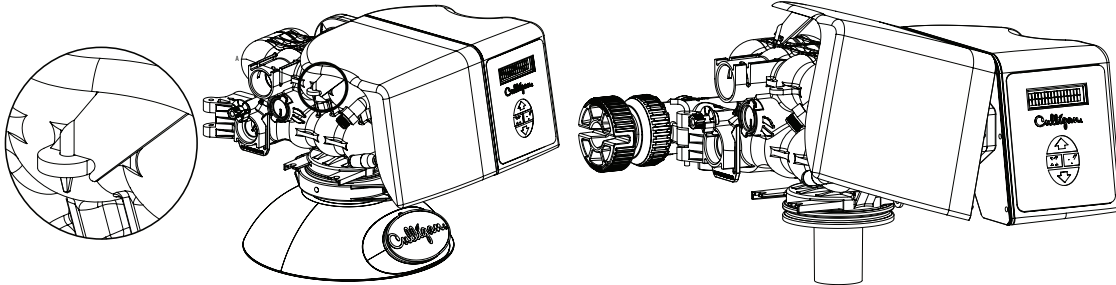

Figure 7. HE softener cover fastener clip.

Figure 8. Removing the HE softener cover.

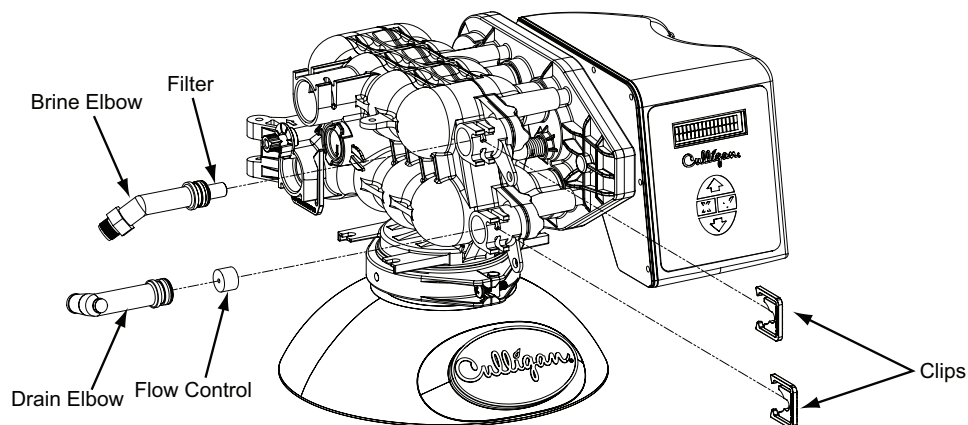

Figure 9. Removing the drain elbow and brine elbow.



### Attaching the Cover

Once the drain and brine line is connected, re-attach the cover.

1. Insert the two pins on the top of the cover into the two holes on top of the frame; the cover should be slightly angled. See Figure 10.
2. Rotate the cover downward inserting the two pins on the side of the cover into the two holes on side of the frame. See Figure 11.
3. Attach the cover fastener onto the control valve. See Figure 12.

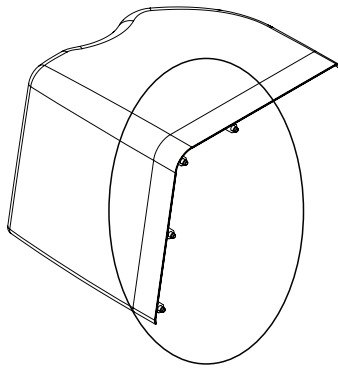

Figure 10. Cover fastener clip.

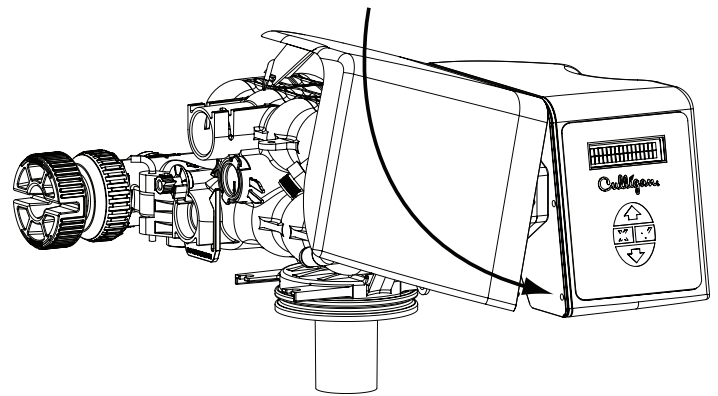
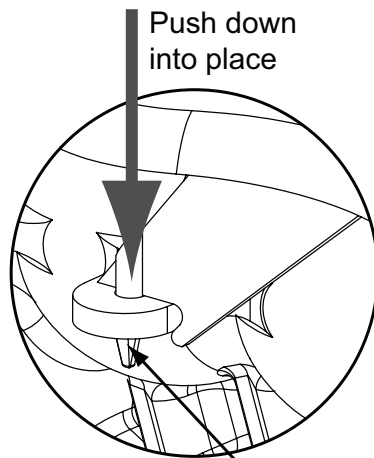

Figure 11. Reattaching the HE softener cover.



Cover  
Fastener

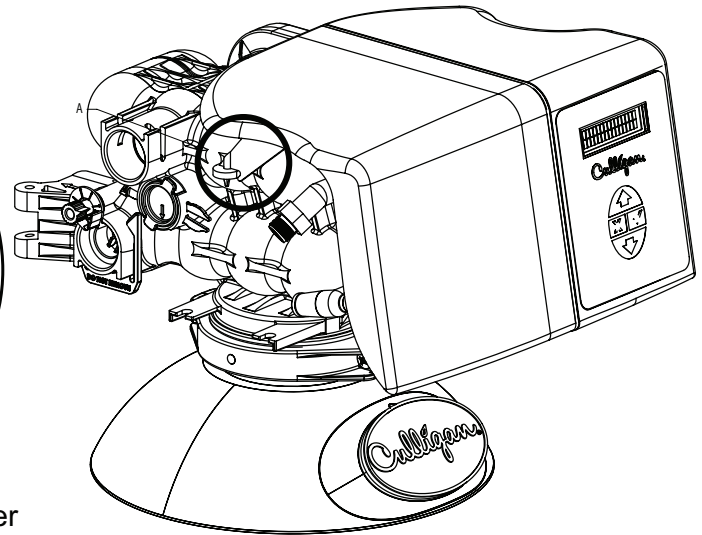

Figure 12. Reattaching the cover fastener.



## Dial-a-Softness

Dial-a-Softness is a manual adjustment built into the control valve that allows for variable hardness bypass into the softened water. The hard water bypass can be adjusted to produce 1–3 gpg hardness bleed. Shipped from the factory the Dial-a-Softness knob is set to the “SOFTEST” position (no hard water bypass). See Figure 13.

To set the Dial-a-Softness:

1. Locate the Dial-a-Softness knob on the control valve.
2. Set the Dial-a-Softness knob to position A, B, or C as outlined in the table below, based on raw water hardness; this should produce a 1–3 gpg hardness bleed.

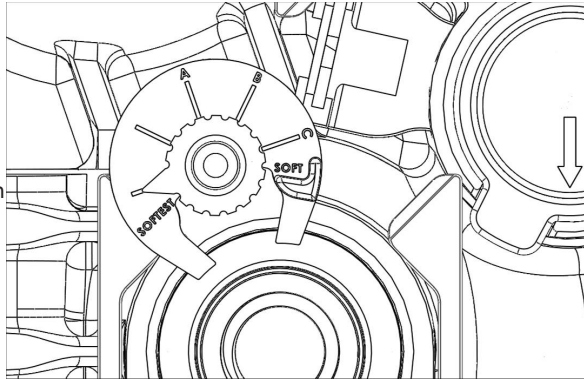

Figure 13. Dial-a-Softness knob.

Letter on Dial-a-Softness Knob	1–3 gpg Hardness Bleed
SOFTEST	0
A	Greater than 20 gpg
B	Between 10–20 gpg
C	Less than 10 gpg

**NOTE** The HE must take into account the adjusted capacity if the Dial-a-Softness was changed. See **Advanced System Setup** to update the Dial-a-Softness setting.

## Plumbing Connections

Shipped with each softener is a Culligan® bypass valve, which is used to connect the softener to the plumbing system. The bypass allows the softener to be isolated from the water service line if service is necessary while still providing water to the home. The bypass valve can be directly plumbed into the system, or can be connected with the following optional sweat connection kits.

- P/N 01010783 1" Sweat Copper Adapter Kit
- P/N 01016564 3/4" Sweat Copper Adapter Kit
- P/N 01016565 3/4" Elbow Sweat Copper Adapter Kit
- P/N P1018757 1" NPT Plastic Elbow Adapter Kit
- P/N P1018758 1" NPT Plastic Installation Kit



**CAUTION!** Close the inlet supply line and relieve the system pressure before cutting into the plumbing! Flooding could result if not done!



**CAUTION!** When making sweat connections, use care to keep heat away from the plastic nuts used to connect the plumbing to the bypass. Damage to these components might result otherwise.



## Bypass Valve Installation

Refer to Figure 14 and the instructions below to connect the meter, bypass valve, and interconnecting pipe.

1. All HE units are equipped with a Soft-Minder® meter. The meter is installed on the outlet side of the control valve. The meter body fits in the same space as the coupling between the control valve and the bypass. Make sure the arrow on the flow meter is pointing in the direction of the flow.
2. The bypass valve connects directly to the control valve with the meter and coupling and two assembly pins. Lubricate all O-rings on the couplings/meter with silicone lubricant.

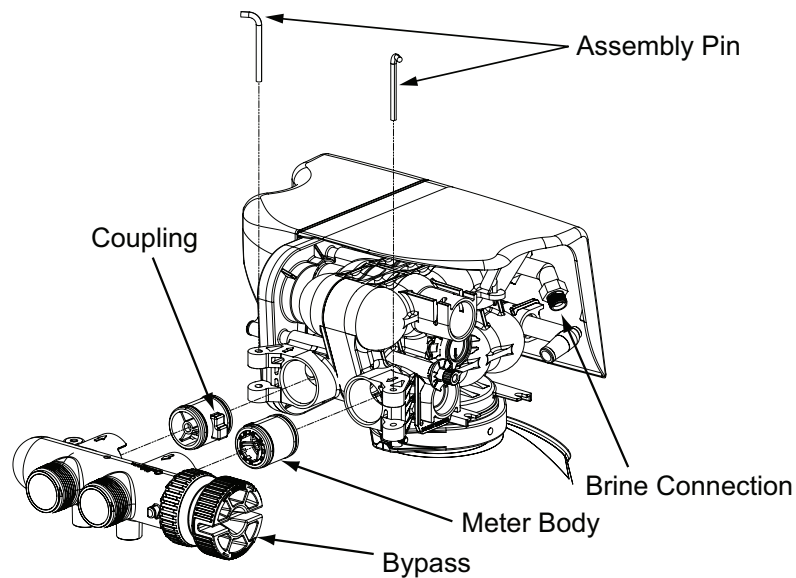

Figure 14. Bypass valve assembly.

**NOTE** The new Low Flow Meter has a white dot on the connection for the wire harness.

**NOTE** If the ground from the electrical panel or breaker box to the water meter or underground copper pipe is tied to the copper water lines and these lines are cut during installation of the bypass valve, an approved grounding strap must be used between the two lines that have been cut in order to maintain continuity. The length of the grounding strap will depend upon the number of units being installed. In all cases where metal pipe was originally used and is later interrupted by the bypass valve to maintain proper metallic pipe bonding, an approved ground clamp c/w not less than #6 copper conductor must be used for continuity. Check your local electrical code for the correct clamp and cable size.





## Drain Line Connection

Refer to Table 3 for drain line length and height limitations under the applicable tank size.

1. Remove 1/2" pipe clamp from the small parts pack included with the control.
2. Route a length of 1/2" drain line from the drain elbow to the drain.
3. Fasten the drain line to the elbow with the clamp.
4. Secure the drain line to prevent its movement during regeneration. When discharging into a sink, or open floor drain, a loop in the end of the tube will keep it filled with water and will reduce splashing at the beginning of each regeneration.

**NOTE** Waste connections or drain outlets shall be designed and constructed to provide for connection to the sanitary waste system through an air gap of two pipe diameters or 1 inch, whichever is larger.

**NOTE** Note: Observe all plumbing codes. Most codes require an anti-siphon device or air gap at the discharge point. The system and installation must comply with state and local laws and regulations.

Operating Pressure	0 ft (0 m)	2 ft (0.6 m)	4 ft (1.2 m)	6 ft (1.8 m)	8 ft (2.4 m)	10 ft (3 m)
30 psi (210 kPa)	60 ft (18 m)	50 ft (15 m)	30 ft (9 m)	15 ft (5 m)	Not allowable	Not allowable
40 psi (279 kPa)	100 ft (30 m)	90 ft (27 m)	70 ft (21 m)	50 ft (15 m)	30 ft (9 m)	12 ft (4 m)
50 psi (349 kPa)	145 ft (41 m)	115 ft (35 m)	80 ft (24 m)	80 ft (24 m)	60 ft (18 m)	40 ft (12 m)
60 psi (419 kPa)			100 ft (30 m)	100 ft (30 m)	85 ft (26 m)	60 ft (18 m)
80 psi (559 kPa)	Normal installation should not require				140 ft (43 m)	120 ft (37 m)
100 psi (699 kPa)	more than 100 ft (30 m) of drain line					150 ft (46 m)

Table 3. Height of Discharge Above Floor Level Operating.

## Connect the Brine Line

1. Measure a length of brine line sufficient to reach from the brine tank to the brine fitting, with no sharp bends. For easier access to the float it is recommended to add an extra four feet (1.3 meters) of length to the brine line.
2. Cut both ends of the brine line squarely and cleanly.
3. Slip the white nut over one end of the tubing and press the plastic insert into the end of the tubing (Figure 15). Connect to the brine valve and tighten nut.
4. Remove white nut and plastic insert from the small parts pack.
5. Slip the white nut over one end of the tubing and press the plastic insert into the end of the tubing (Figure 15). Connect to the brine connection on the valve and tighten nut.

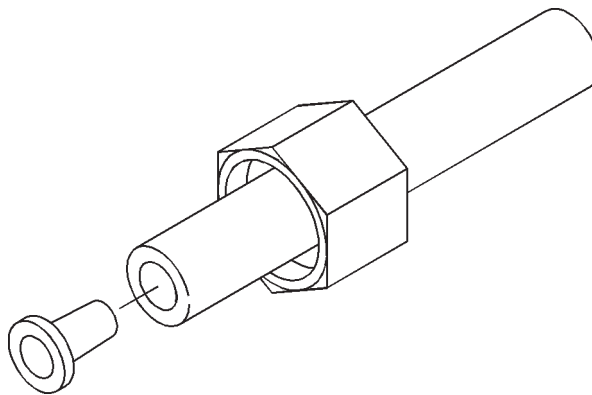

Figure 15. Brine valve tubing.



### Fill The Salt Storage Container

Fill the salt storage container with water until the level reaches about 1 inch above the salt support plate. Pour salt into the container. Fill with salt to within a few inches of the top.

### Brine Valve "A" Dimension

The brine valve contains a brine float which can serve as a backup refill shutoff in the event of a failure, such as a power outage when in the refill position. The float level should be set based on the salt dosage setting. Refer to Figure 16.

1. Remove nut retaining brine valve to brine chamber.
2. Lift the brine valve from the brine chamber.
3. Find the correct "A" dimension in the HE Softener Installation/Operation manual (PN 01021606).
4. Set the distance from the top of the filter screen to the base of the float accordingly. The slight difference in height when the float is pulled up or down is negligible.
5. Re-install into brine chamber and replace nut.

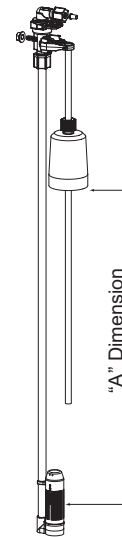

Figure 16. Brine valve "A" dimension.

### Circuit Board Connections

The 24 Volt power supply and flow meter wire harness is already connected to the circuit board. If no other circuit board connections are required proceed to the First Time Setup. Refer to the instructions below and [Figure 17](#) to [Figure 20](#) for connecting the Aqua-Sensor probe wire harness to the circuit board.



**WARNING!** Disconnect all electrical power to the unit before connecting.



**CAUTION!** Grip all connections to the circuit board by the connecting terminals for assembly and disassembly. Failure to do so could result in damage to the wire leads or connecting terminals.



**CAUTION!** Do not touch any surfaces of the circuit board. Electrical static discharges might cause damage to the board. Handle the circuit board by holding only the edges of the circuit board. Mishandling of the circuit board will void the warranty.

**NOTE** Observe all state and local electrical codes.



1. Remove the electrical enclosure from the control valve. First remove the electrical enclosure screw and then gently remove the enclosure from the control. Refer to Figure 17 and below instructions.

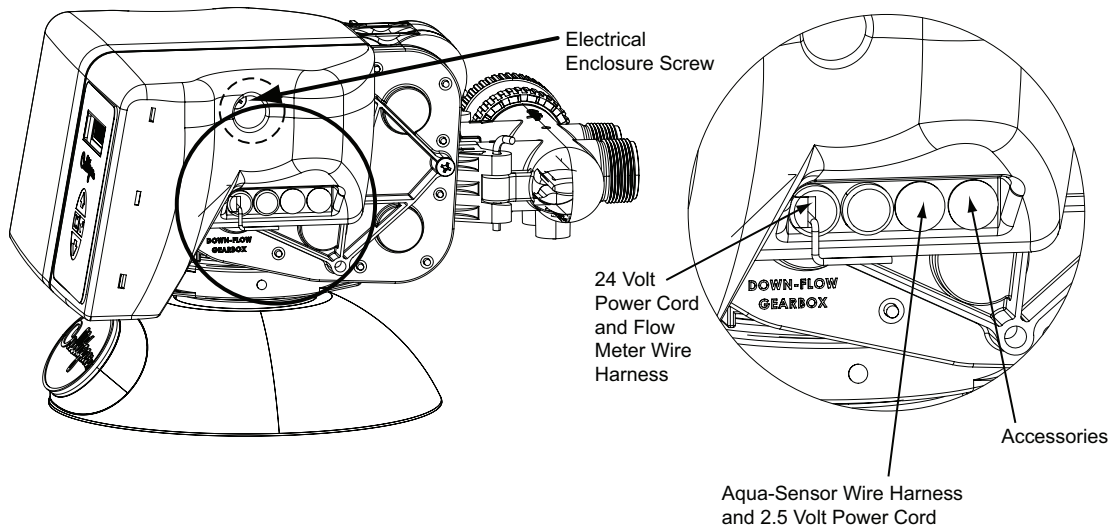

Figure 17. Circuit board connections.

2. Remove the 24 V power supply wire harness from the circuit board. See [Figure 18](#).
3. Grip the circuit board from the edges and gently rotate it to the back of the enclosure (you are disengaging the circuit board from the two support pins on the bottom of the enclosure).
4. Remove the circuit board from the enclosure. See [Figure 19](#).
5. Remove the plastic plugs from the enclosure.
6. Locate the Aqua-Sensor 2.5 VAC power cord packed in the small parts pack. It has two spade terminals on one end of the cable and two metal slip-in tabs on the other end.
7. Insert the Aqua-Sensor 2.5 VAC power cord through the third hole on the enclosure. Insert the Aqua-Sensor sensor probe wire harness through the fourth hole on the enclosure. See [Figure 17](#).

**NOTE** If additional accessories are to be connected to the circuit board (such as the Smart Brine Tank Probe or a phone line for modem) insert both the Aqua-Sensor 2.5 Volt power supply wire harness and the Aqua-Sensor sensor probe wire harness through the third hole on the enclosure.

8. Connect Aqua-Sensor probe wire harness to the circuit board. The Aqua-Sensor probe terminal is labeled "Aqua-Sensor." See [Figure 20](#).

**NOTE** The wire connectors must be connected to the circuit board properly. The wires must exit the plug-in connector opposite of the raised white base of the circuit board connector. Failure to properly connect any of the connectors will result in a malfunction of the circuit board operation.

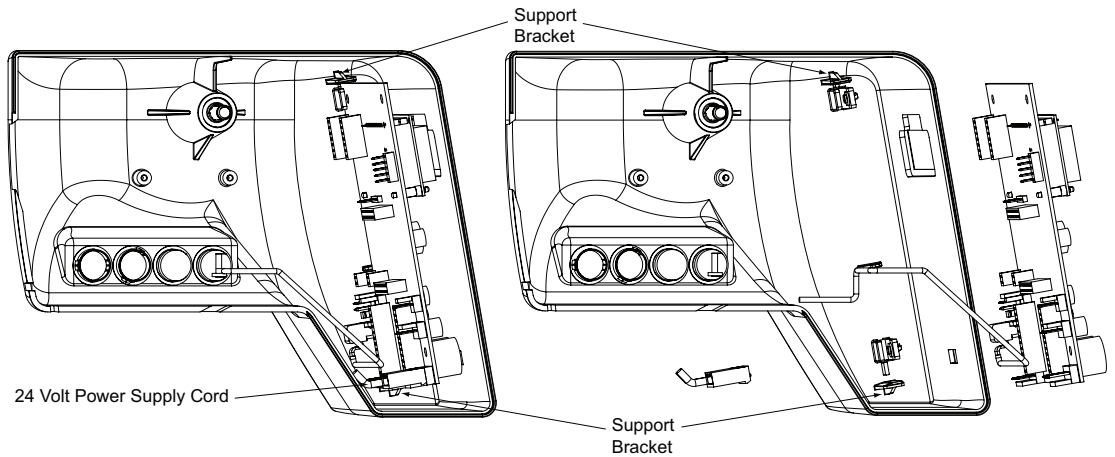

Figure 18. Circuit board power supply.

Figure 19. Circuit board removal.

9. Install the Aqua-Sensor 2.5 volt power cord.
  - a. The power connection to the circuit board should be **INSIDE** the controller. The spade terminals should be connected to the transformer.
  - b. Discard the dummy connector on the 2.5VAC circuit board pins.
  - c. Connect the Aqua-Sensor power cord to the 2.5VAC pins on the circuit board.
  - d. Connect the other end of the power cord, with the spade terminals, to the two 2.5 VAC terminals on the transformer. See [Figure 20](#).
10. Pull any excess cable wire out of the enclosure and route the wiring inside the enclosure to avoid interference.
11. Insert the circuit board back into the enclosure.
  - a. Angle the circuit board opposite the front enclosure and into the support bracket on the side of the enclosure.
  - b. Gently push down and rotate forward until you hear a click (the pins on the bottom of the enclosure being inserted into the circuit board).
  - c. Check to make sure the circuit board is rigidly fastened.

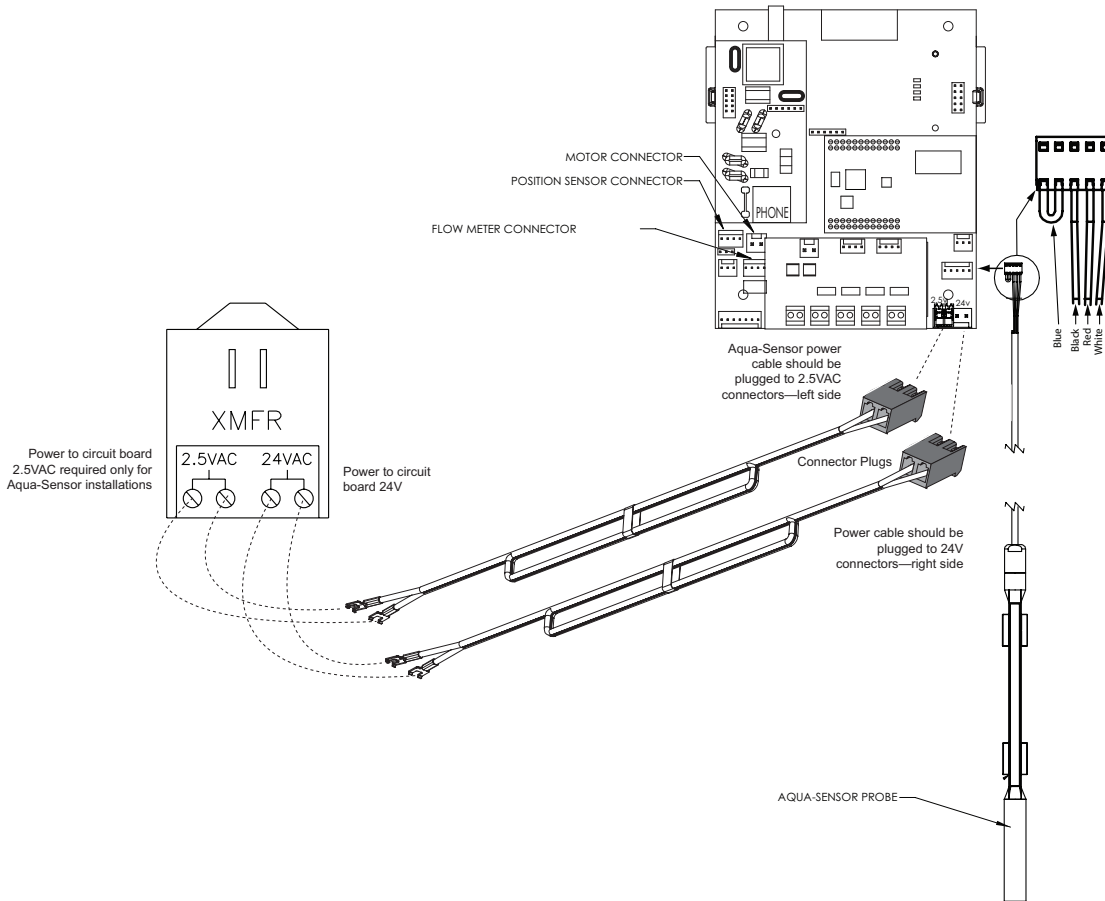

Figure 20. 2.5 VAC Aqua-Sensor® power connection.

12. Connect the power supply cord to the circuit board.



**CAUTION!** Verify wiring from the terminals to circuit board are correct before applying power to the control. 24 V power must not be applied to the 2.5 VAC terminals.



**CAUTION!** Connecting 24 V to the 2.5 VAC connection on the circuit board will damage the circuit board.

13. Reattach the electrical enclosure cover to the control valve.

- a. Align the circuit board in the enclosure with the three support brackets on the control valve frame. See [Figure 21](#).
- b. Push the enclosure onto the control valve, inserting the circuit board edge in the slots on the control valve frame and the screw on the enclosure with the hole on the cover.

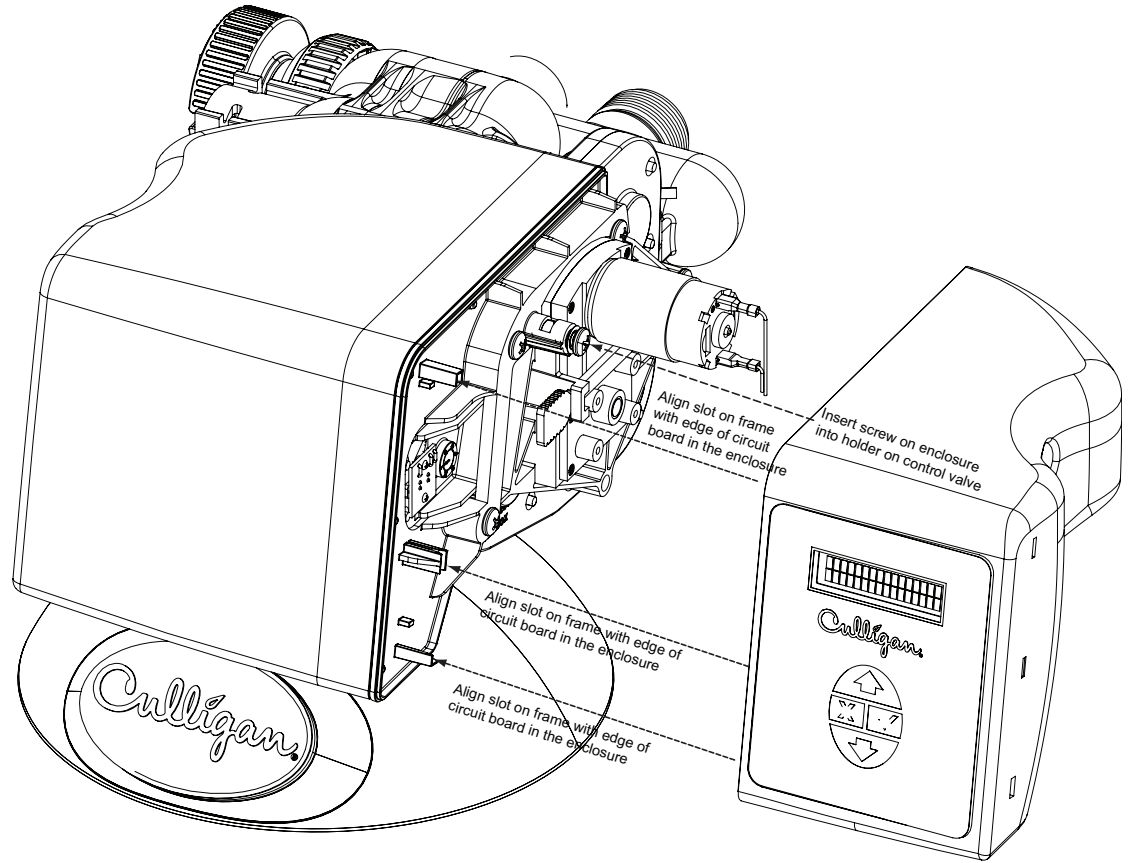
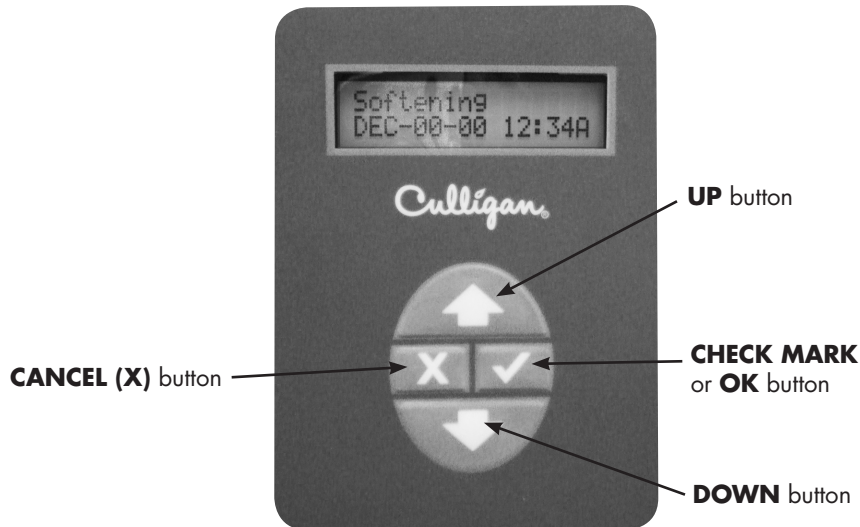

Figure 21. Attaching enclosure cover to control valve.

- c. Screw the enclosure on the control.
- d. Attach the strain relief fittings to the Aqua-Sensor probe and 2.5 VAC power cord and insert into the enclosure.
- e. Connect the 24 V power cord to the two 24 V terminals on the transformer.



## Navigating the Menus and Keypad



**UP ARROW** button: scrolls up the menu



**DOWN ARROW** button: scrolls down the menu



**CHECK MARK** button: selects the highlighted option, opens a new screen, or accepts a changed setting



**CANCEL** or **X** button: returns to the previous screen or cancels a changed setting

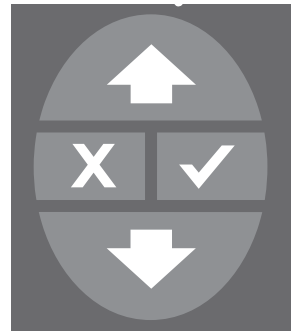

Controller



Remote

**NOTE** Hold down  or  to quickly scroll through the setting without repeatedly pressing the button.

Softening  
JAN-01-13 12:01P

1. This is the **HOME SCREEN**. Press any button except  to advance to the **MAIN MENU SCREEN**.

>1) INFORMATION  
2) MANUAL MODE

2. This is the **MAIN MENU SCREEN**. The ">" symbol indicates the menu selection. Press  or  to scroll through the menu.



1) INFORMATION  
>2) MANUAL MODE





3. This is the **MAIN MENU SCREEN**. The ">" symbol indicates the menu selection. Press  or  to scroll through the menu.

MANUAL MODE  
REGEN NOW

4. Press  to select a setting.

5. The screen displays the setting (Manual Mode) and the current value (Regen Now). Press  to change the value.

MANUAL MODE  
>REGEN NOW

6. The screen displays the ">" symbol next to the value, indicating that the value may be changed. Press  or  to change the value. For example, press  to change the value to **REGEN TONITE**. Press  again to select the next available value, **BYPASS**.

MANUAL MODE  
REGEN NOW

7. Press  to cancel the changed setting and revert to the default setting. The screen displays the default setting.

MANUAL MODE  
>BYPASS

8. Press  to accept the changed value. If the setting values are displayed, the ">" symbol no longer appears next to the value.

1) INFORMATION  
>2) MANUAL MODE

9. The screen then returns to the **MAIN MENU**. Press  to return to the **HOME SCREEN**.

Softening  
JAN-01-13 12:01P

10. The screen displays the **HOME SCREEN**.

**NOTE** Unplugging the Culligan HE water softener will not affect any of the control settings (the control must be plugged in for at least 10 minutes). Once programmed, the settings will be stored indefinitely.





## First Time Setup

### First Time Setup Procedure

When a new controller is first powered on, the screen will display the first time setup message. The HE Controller is designed to simplify the setup and installation process by making some default recommendations during the initial setup. These default settings are appropriate for most common installations.

After completing the plumbing connections to the water softener, turn on and program the HE Controller.

```
FIRST TIME SETUP  
PRESS DOWN ARROW
```

When a new controller is first turned on, the screen displays **FIRST TIME SETUP**. Press  to display the first setup screen.

### Serial Number

```
S/N: 00000123
```

The screen displays the serial number for this Smart Controller. Press  to display the firmware version information screen.

**NOTE** If this unit will be installed with a modem, it is required that this electronic ID number be reported to Culligan on the IQR form.



### Firmware Version

```
FWR***LT21  
MON DD YEAR
```

The screen displays the firmware version and date installed for this Smart Controller. Press  to display the month setup screen.

### Set Month (Jan-Dec)



```
SET MONTH  
>JAN
```



The screen displays the month setting. Press  to accept the information displayed (and view the next setting), or press  to change the setting.

Press  to accept the selected month and advance to the next setting, **SET DAY**.

### Set Day (0-31)



```
SET DAY  
>1
```



The screen displays the day setting. Press  to accept the information displayed (and view the next setup screen), or press  to change the setting.

Press  to see the next available value. Press  to accept the selected day and advance to the next setting, **SET YEAR**.

### Set Year (2009-2030)

```
SET YEAR  
>2013
```

The screen displays the year setting. Press  to accept the information displayed (and view the next setup screen), or press  to change the setting.

Press  to see the next available value. Press  to accept the selected year and advance to the next setting, **CLOCK TYPE**.



### Set Clock Type (12 or 24)

CLOCK TYPE  
>12 HR

The screen displays the clock type setting. Press  to accept the information displayed (and view the next setup screen), or press  to change the setting.

Press  to change the clock type from 12-hour to 24-hour. Press  to accept the selected clock type and advance to the next setting, **SET HOUR**.

### Set Hour (12PM-11AM)

SET HOUR  
>12AM

The screen displays the hour setting. Press  to accept the information displayed (and view the next setup screen), or press  to change the setting.

Press  to change the hour (in this example, from 12PM to 10AM). Press  to accept the selected hour and advance to the next setting, **SET MINUTES**.

### Set Minutes (0-60)

SET MINUTES  
>01

The screen displays the minutes setting. Press  to accept the information displayed (and view the next setup screen), or press  to change the setting.

Press  to change the minutes (in this example, from 0 to 20). Press  to accept the selected hour and advance to the next setting, **UNIT TYPE**.

### Unit Type (Softener, Filter, or Resin + Carbon)

UNIT TYPE  
>SOFTENER

The screen displays the unit type setting. Press  to accept the default setting (softener) and advance to the next setting, **VALVE TYPE**.

### Valve Type (HE 1, HE 1.25, HE 1.5, HE 1 Twin, HE 1.5 Twin, 4-Cycle, 5-Cycle, or Plat Plus)

VALVE TYPE  
>HE 1

The screen displays the valve type setting. Press  to accept the default setting (**HE 1**) and advance to the next setting, **UNITS**.

### Units (US or Metric)

UNITS  
>US INCH

The screen displays the units of measure setting. Press  to accept the default setting (US INCH) and advance to the next setting, **INSTALL TYPE**.

### Install Type (Residential or Commercial)

INSTALL TYPE  
>Residential

The screen displays the installation type setting. Keep this at the default, **Residential**. Press  to view the next setting, **BRINING TYPE**.



### Brining Type (Downflow, Upflow, Proportional)

BRINING TYPE  
>Downflow

The screen displays the brining type setting. Press   or  and then  to change this setting to **Downflow** and view the next setting, **TANK DIAMETER**.

### Tank Diameter (9, 10, 12, 14)

TANK DIAMETER  
>10

The screen displays the tank diameter setting. Press   or  and then  to change the value and view the next setting, **WATER HARDNESS**.

### Water Hardness (1-170)

HARDNESS GPG  
25 (1109 GAL)

The screen displays the water hardness setting in grains per gallon. Press   or  and then  to change the value and begin initialization.

### Completed First Time Setup

Initializing  
JAN-01-13 12:01P

When the setup is complete, the circuit board microprocessor automatically calculates softener capacity. The screen displays the initializing status and the current date and time, and then transitions to the home screen.

SOFTENING  
JAN-01-13 12:01P

The screen displays the current state (the display alternates between Softening and any error) and the date/time set for the unit. This is the default home screen.

The controller is designed to simplify the setup and installation process by making some default recommendations during the Initial Setup. The default settings are designed to be appropriate for most common installations.







## Set Date and Time

Follow this procedure to update the date or time.

**NOTE** The control must be returned to the HOME screen if settings are changed.

Screen Display	Range	Setting Description
SOFTENING JAN-01-13 12:01P	N/A	1. From the <b>HOME</b> screen, press  to view the main menu.
>1) INFORMATION 2) MANUAL MODE	1-6	2. The screen displays the main menu. Press    to select <b>3)SET DATE/TIME</b> .
<b>Set Month</b>		
SET MONTH >JAN	Jan-Dec	3. The screen displays the month setting. Press   or  and then  to change the setting.
<b>Set Day</b>		
SET DAY >1	1-31	4. The screen displays the day setting. Press   or  and then  to change the setting.
<b>Set Year</b>		
SET YEAR >2013	2009- 2030	5. The screen displays the year setting. Press   or  and then  to change the setting.
<b>Set Clock Type</b>		
CLOCK TYPE > 12 HR	12 HR, 24 HR	6. The screen displays the clock type setting. Press   or  and then  to change the setting.
<b>Set Hour</b>		
SET HOUR > 12PM	12PM- 11AM, 0-23	7. The screen displays the hour setting. Press   or  and then  to change the setting.
<b>Set Minutes</b>		
SET MINUTES >1	0-59	8. The screen displays the minutes setting. Press   or  and then  to change the setting.



Screen Display	Range	Setting Description
<b>Set Daylight Savings Time</b>		
DAYLIGHT SAVING YES	Yes, No	9. The screen displays the Daylight Savings Time setting. Press   or  and then  to change the setting.
2) MANUAL MODE >3) SET DATE/TIME		10. The screen displays the main menu. Press  to save the changes and initialize the system.
SOFTENING JAN-01-13 12:01P		11. The screen displays the home screen.







## Information

The following information can be displayed at the control valve or remote display. These settings are read-only. Press or to scroll through the settings. Press to view the previous setting.

Screen Display	Range	Setting Description
SOFTENING JAN-01-13 12:01P	N/A	1. From the <b>HOME</b> screen, press  to view the main menu.
>1) INFORMATION 2) MANUAL MODE	1-6	2. The screen displays the main menu. Press  to select <b>1) INFORMATION</b> .
SALT TANK LEVEL OK	OK, Low	3. If a Smart Brine Tank is installed, this screen displays the salt level. The status is <b>OK</b> unless the SBT probe detects an overfilled brine tank or low salt level. If the screen displays <b>LOW</b> a subsequent screen displays <b>APPROX DAYS OF SALT REMAINING</b> . Press  to select the next information screen.
REMAIN CAPACITY 100%	0-100	4. The screen displays the softening capacity remaining, displayed as a percentage of the total capacity. During manually initiated regeneration, assume 0 percent remaining capacity. Press  to select the next information screen.
REMAIN CAPACITY 740 GAL	0-no limit	5. The screen displays the softening capacity remaining, measured in gallons (liters). Press  to see the next information screen.
CURRENT FLOWRATE 0.0 GPM	0-no limit	6. The screen displays the current flow rate, measured in gallons (liters) per minute. Press  to see the next information screen.
TODAY'S USAGE 0 GAL	0-no limit	7. The screen displays today's water usage, measured in gallons (liters). Press  to see the next information screen.
AVERAGE DAILY 300 GAL	0-no limit	8. The screen displays average water usage for this configuration. Press  to see the next information screen.



Screen Display	Range	Setting Description
NEXT REGEN ON JAN-03	N/A	9. The screen displays the date of the next regeneration, based on average daily water usage. Press  to see the next information screen.
TOTAL WATER USED 1000 GAL	0-no limit	10. The screen the total water used for this configuration. Whole numbers are displayed above 100 gallons. Press  to see the next information screen.
EXT FILT CAP REM 20000 GAL	0-no limit	11. If an external filter is used, the screen displays the remaining capacity of the filter. When the remaining capacity reaches zero, the system triggers the External Filter Alarm. Press  to return to the main menu.
>1) INFORMATION 2)MANUAL MODE		12. The screen displays the main menu. Press  to exit to the home screen.
SOFTENING JAN-01-13 12:01P		13. The screen displays the home screen.



## Regeneration

There are several conditions that will cause the control to trip a regeneration. The screen displays **REGEN Tonite** when the control has signaled for a regeneration. Regenerating is displayed while the control is in regeneration. The following are conditions that will call for regeneration:

1. When the Soft-Minder® meter has recorded the passage of a predetermined number of gallons.
2. When the Aqua-Sensor® Probe senses the hardness in the Cullex Media.
3. At the preset time, when the number of days without a regeneration is equal to the regeneration interval (timeclock backup) setting.
4. At the preset time, when Regen Tonite is selected. The screen displays Regen Tonite.
5. Immediately, when the Regen Now is selected. The screen displays Regenerating.
6. Immediately, if power to the unit has been off for more than three hours and the time of day has been restored.
7. At the preset time based on "Day-of-Week" Regeneration setting.

Follow either procedure to bypass the softener or to initiate a manual regeneration or automatically bypass the softener at the control valve or the remote display.

### Delayed Regeneration

Screen Display	Range	Setting Description
SOFTENING JAN-01-13 12:01P	N/A	1. From the <b>HOME</b> screen, press <input checked="" type="checkbox"/> and hold for at least three (3)seconds and then release the button.
REGEN TONITE JAN-01-13 12:01P	Regen Tonite	2. The screen displays the regeneration status on the first line of the display. The system will regenerate at a scheduled time.
REGEN OFF JAN-01-13 12:01P	Regen Off	3. To cancel a delayed regeneration, press <input checked="" type="checkbox"/> and hold for at least three (3) seconds and then release the button. The screen displays the new status.

### Immediate Regeneration

Screen Display	Range	Setting Description
SOFTENING JAN-01-13 12:01P	N/A	1. From the <b>HOME</b> screen, press <input checked="" type="checkbox"/> and hold for at least ten (10) seconds.
REGEN NOW JAN-01-13 12:01P	Regen Now	2. The screen displays the regeneration status on the first line of the display. The softener will initiate an immediate regeneration.
REGENERATING JAN-01-13 12:01P	N/A	3. The first line of the screen displays <b>REGENERATING</b> .





## Standard Manual Regeneration

Screen Display	Range	Setting Description
SOFTENING JAN-01-13 12:01P	N/A	1. From the <b>HOME</b> screen, press  to view the main menu.
1) INFORMATION >2) MANUAL MODE	1-6	2. The screen displays the main menu. Press   to select <b>2)MANUAL MODE</b> .
MANUAL MODE >REGEN NOW	Regen Off Regen Now Regen Tonight Bypass	3. The screen displays the manual regeneration menu. Press   or  and then  to change the setting.  <b>REGEN NOW</b> is the default. <b>REGEN OFF</b> specifies the softener will not regenerate. <b>REGEN TONITE</b> specifies that the softener will regenerate that night at 2:00 a.m. (or at the preset regeneration time). The screen displays two status messages: <b>SOFTENING</b> and <b>REGEN TONITE</b> . <b>BYPASS</b> specifies a preset softener bypass time. Press  to select the total time the softener is in the bypass state.
MANUAL BYPASS OFF	Off, 30, 60, 90, 120, 180, Manual Bypass	4. The screen displays the manual bypass duration, in minutes. This specifies the total time the softener is to be in the bypass state. Press   or  and then  to change the setting.
SOFTENING JAN-01-13 12:01P	N/A	5. Press   to display the home screen.



## Final Startup

### Recommended Meter Start-Up Procedure

1. Close the main water supply valve.
2. Set the Cul-Flo-Valv® to the bypass position.
3. Ensure that all faucets at the installation site are closed.
4. Direct the drain line discharge into a bucket where flow can be observed.
5. Plug the transformer into a 120 Volt, 60 Hz, single-phase receptacle. The screen displays **FIRST TIME SETUP**.
6. Complete the First Time Setup.
7. Open the main supply valve.
8. Initiate an immediate regeneration to move the control into the **BACKWASH** position.
9. Refer to the section on manual cycling for information on cycling the control through its positions.
10. When in the **BACKWASH** position, slowly rotate the bypass to the soft water position until water flows.
11. Allow the tank to fill slowly until water flows from the drain line.
12. When flow to drain is established, open the bypass fully. Watch the drain line discharge for signs of resin. If signs of resin particles appear, reduce the flow. Increase the flow again when resin no longer appears in the discharge.
13. After the **BACKWASH** runs clear, step the control to the **REFILL** position to fill the brine tank and purge air from the brine line.
14. Complete the installation and cleanup.
15. Sanitize the unit as you leave the installation site. See [“Sanitizing Procedure” on page 43](#).
16. Initiate an immediate regeneration, or set to regenerate at the preset time.



## Recommended Aqua-Sensor® Start-Up Procedure

**NOTE** You might find it useful to pre-test the sensor probe in your shop. The same test setup can be used in the field.

1. Close the main water supply valve.
2. Install the sensor probe into the tank but do not connect the sensor to the control at this time.
3. Set the Cul-Flo-Valv® to the **BYPASS** position.
4. Ensure that all faucets at the installation site are closed.
5. Direct the drain line discharge into a bucket where flow can be observed.
6. Plug the transformer into a 120 Volt, 60 Hz, single-phase receptacle (make sure to connect both 24V and 2.5V properly).
7. Complete the First Time Set-up.
8. Open the main supply valve.
9. Initiate an immediate regeneration to move the control into the **BACKWASH** position.
10. Refer to the section on manual cycling for information on cycling the control through its positions.
11. When in the **BACKWASH** position, slowly rotate the bypass to the soft water position until water flows.
12. Continue **BACKWASH** until the drain effluent is clear and the Aqua-Sensor probe is placed in the resin bed—at least 10 minutes (use a white foam coffee cup to occasionally collect a sample of backwash water; the stark white of the cup will show the presence of color throw and resin fines).
13. Continue or repeat the **BACKWASH** cycle if needed.
14. After the backwash water runs clear, step the control to the **REFILL** position to fill the brine tank and purge air from the brine line.
15. Unplug the control and connect the sensor to the circuit board.
16. Reconnect the power and INSTALL the Aqua-Sensor Probe (Main Menu/ Accessories/ AquaSensor)
17. Check the condition of the Aqua-Sensor (Main Menu/ Diagnostics/ Checksensors)
18. Press the Program key and program the control to the desired settings.
19. Complete installation and cleanup.
20. Sanitize the unit as you leave the installation (see ["Sanitizing Procedure" on page 43](#)).
21. Initiate an immediate regeneration.

The thorough backwashing process should have cleared the fines and color-throw from the tank. The probe should settle into the resin bed during the first couple of minutes of backwashing.



## Salt Supply, Usage and Service

Salt is the mineral used to “recharge” your water conditioner. A brine solution is automatically made up in the bottom of the salt storage container, the Cullex® resin beads in the mineral tank are flushed with the brine solution as a step in the recharging process.

Your Culligan Water Conditioner has been carefully designed to get the greatest amount of softening capacity from the salt it uses. Here is some pertinent information about salt usage, types and service.

### Salt Economizer

This control is set at the time of installation, and determines salt usage according to the water hardness, number of persons in the household, and water usage.

### What Kind of Salt is Best

All Culligan Water Conditioners are designed to use any water conditioner salt of good quality, including rock, pellet, solar, or “evaporated” types.

All rock salt, regardless of source, contains insoluble material which collects at the bottom of the salt storage tank and requires periodic clean-out.

If purified salt products are used, the salt storage compartment will require less frequent clean-out, but you must check more frequently for “bridging.”

Regardless of what type of salt is used, we recommend Culligan Brand Salt as suggested by your Culligan Dealer. He or she is the expert and can provide you with the best product for your Culligan Water Conditioner.

### Automatic Salt Delivery Service

Ask your Culligan Dealer for details about salt delivery service. You can have your salt supply replenished on a regular basis. Whether you have automatic delivery service or pick up salt from your Culligan Dealer, you will be getting quality salt packaged according to rigid Culligan specifications. Using Culligan Brand Salt will help assure continued efficiency and trouble-free operation of your water conditioner.

The modem allows for the system to be remotely monitored, detecting problems before they occur, to schedule salt delivery when it is needed and to keep the system software up to date with the latest advances.

<b>NOTICE</b>	<b>Sodium Information: Water softeners using sodium chloride for regeneration add sodium to the water. Persons who are on sodium restricted diets should consider the added sodium as part of their overall sodium intake.</b>
---------------	--



## Care and Cleaning of Your Water Conditioner

Following these simple precautions will help assure continued trouble-free service and keep your Culligan Water Conditioner looking like new for years.

1. Do not place heavy objects on top of the salt storage tank or timer cover.
2. Use only mild soap and warm water when cleaning the exterior of the conditioner. Never use harsh, abrasive cleaning compounds or those which contain acid, such as vinegar, bleach and similar products.
3. Important: Protect your water conditioner and the entire drainline from freezing temperatures.



**WARNING! DANGER: If your unit should freeze, do not attempt to disassemble it. Call your Culligan Dealer.**

4. Important: Culligan water softeners are sold for use on potable water only. If at any time the water becomes contaminated, such as during a “boil water” advisory, the operation of the water softener should be discontinued until it is verified that the water is again potable. To do this, turn the blue knob in a clockwise position, then call your Culligan dealer to have your system sanitized before it is placed back into service.
5. Should service, adjustment or trouble-shooting information be needed which is not covered in the Use and Care Guide, call your Culligan Dealer.

For parts and service availability please call your local independently operated Culligan dealer. For your nearest Culligan dealer, call (800) 285-5442.

### Recommended Preventative Maintenance Inspection Schedule

The Culligan High Efficiency household water softener has been designed to provide a good, consistent service life. Routinely inspecting the system may help avoid potentially costly breakdowns related to circumstances outside of the control of the dealer and/or user.

Component	Suggested Inspection Frequency	Reason for Maintenance
Entire System	At Start-up, after infrequent use (idle for one week or more) or every 3–6 months.	On private supplies, the appearance of off-tastes and odors, particularly if musty or “rotten egg” (caused by harmless sulfate-reducing bacteria) may indicate a need for the system to be sanitized. See <a href="#">page 43</a> .
Backwash Flow Controller	Every 12 months or every time service is performed on the system.	Build up of sediment, iron and/or other foreign materials (found in some water supplies but not necessarily all) could negatively affect system performance. Monitor item for normal or unexpected wear.
Brine eductor nozzle and throat	Every 12 months or every time service is performed on the system.	Build up of sediment, iron and/or other foreign materials (found in some water supplies but not necessarily all) could negatively affect system performance. Monitor item for normal or unexpected wear.
Softening Media (Cullex)	Every 2–3 years	Chlorinated water supplies can breakdown and destroy resin material. Resin material may also perform poorly if subjected to other materials (sediment, iron, alum, etc.) found in some water supplies (but not necessarily all).



## Cleaning Out the Salt Storage Tank

A periodic clean-out of the Salt Storage Tank is necessary to keep your Culligan Water Conditioner at peak operating efficiency. Do it at least every two years when the salt supply is low. Follow these step-by-step procedures:

### Tools Needed

- Scoop
- Clean, bucket-size container
- Garden hose
- Household scrub brush or sponge

### Procedure

1. Remove the salt storage tank cover and the cap from the brine valve chamber.
2. Lift the brine valve out of the brine valve chamber and set aside in an upright position.
3. If you'd like to save any clean, dry salt remaining in the tank, remove it and place it in a clean container.
4. Using the scoop, dig out and discard as much remaining salt, water and debris as possible.
5. Remove the brine valve chamber by removing the screws on either side of the salt tank.
6. Remove the salt plate at the bottom of the brine tank.
7. Lay the salt tank on its side and direct a brisk stream of water from your garden hose to its inside to rinse out all residue.
8. Using a household scrub brush and a mild soapy solution, clean the salt plate. This will complete the tank cleaning.
9. Insert the brine valve into the chamber and replace brine valve chamber cap.
10. Fill the salt storage tank with 4 to 6 inches of water.
11. Fill the tank with salt to within a few inches of the top.
12. Replace salt storage tank cover.



## Sanitizing Procedure

A water softener in daily use on a potable water supply generally requires no special attention other than keeping the salt tank filled. Occasionally, however, a unit may require sanitization under one of the following conditions:

- At start-up time.
- After standing idle for a week or more.
- On private supplies, the appearance of off-tastes and odors, particularly if musty or “rotten egg” (caused by harmless sulfate-reducing bacteria).

**NOTE** If the water supply contains iron, regenerate the softener before sanitizing to remove iron from the resin.



**CAUTION! Caution! Hazard from toxic fumes! Chlorine bleach and common iron control chemicals may generate toxic fumes when mixed.**

If the unit uses Culligan Sofner-gard® or other compounds containing sodium hydrosulfite, sodium bisulfite, or any other reducing agent, disconnect the device feeding the chemical(s) and manually regenerate the unit before sanitizing.

Do not use this procedure if the softener salt contains iron control additives.

1. Remove the brine tank cover.
2. Pour directly into the brine chamber 1/3 to 1/2 cup of common household bleach (5.25% sodium hypochlorite) for each cubic foot of resin in the tank.
3. Manually start recharge. Allow the unit to complete the recharge cycle automatically.

If tastes and odors return frequently, even after sanitization, a continuous chlorination system may be needed. Send a water sample to a qualified laboratory for bacterial analysis.



## Things to Check Before You Call for Service

If you unexpectedly experience changes in your water, make these simple checks before calling your Culligan dealer. One of the following conditions may be the reason for your interruption of service.

### Important

If any of the following conditions is found, the water softener should be manually regenerated according to instructions on [page 37](#) after you have corrected the problem.

### Power Supply

Check your power supply cord. Is it plugged fully into the electric outlet? Be certain that the outlet is not controlled by a wall switch which has been turned off. Plug in the transformer then reset conditioner to the correct time of day.

### Blown Fuse

Check the house fuse or circuit breaker panel. Replace a blown-out fuse or reset an open circuit breaker.

### Power Failure

Any interruption in your power supply or time change—such as daylight savings—will disrupt your softener's regeneration schedule by causing the timer to run off-schedule. Reset the timer to the correct time of day.

### Bypass Valves

Check to see if they are in the proper position. Cul-Flo-Valv<sup>®</sup> Bypass, if used, should be in the "Service" position (see [page 47](#)). If hand valves are used, see that inlet and outlet valve are opened and that the bypass valve is closed.

### No Water

If you aren't getting any water flow at all, make sure your water supply is working. Open a tap ahead of the conditioner (outside tap) to see if you have any water pressure. If you have water pressure, check the bypass valve. If it is in the Service position, put it into the bypass and call your Culligan dealer for service.

### Increased Usage

Guests, family additions, new water-using appliances, etc., will result in more water usage and will require more capacity from your softener. You can reprogram your regeneration schedule by following the directions beginning on [page 36](#). Call your Culligan dealer for advice and save a service call.





## Error Codes

The controller display, as well as the Remote Display (if connected), may display the following errors.

PROBLEM FOUND  
APR-01-13 10:01A

REPLACE FILTER  
MEDIA

-->CLEAR ERRORS

-->GO TO MENU

1. When the controller identifies an error, it is programmed to attempt to correct the error without user input. If the problem persists, the **HOME SCREEN** displays **PROBLEM FOUND**. Press to display the first error present.
2. Press to display any additional errors present.
3. Press and to view action: **CLEAR ERRORS, GO TO MENU**, or **EXIT**. If you select **CLEAR ERRORS**, the controller checks the error status and attempts to clear the error. If the error still exists, the home screen displays **PROBLEM FOUND**. If the error no longer exists the screen displays **SYSTEM OK**.
4. Press to select **CLEAR ERRORS, GO TO MENU**, or **EXIT**.

Error	Reason for Error	Comment/ Clearing Error Message
Aqua Salt Err	Aqua-Sensor did not detect brine during the regeneration cycle.	Check brine tank and add salt if necessary. Check Z ratio of the Aqua-Sensor at Main Menu/Advanced/Diagnostics/Check Sensors
Aqua Sens Probe	An Aqua-Sensor was "Installed" but main board detects the Aqua-Sensor is not connected. The board might not be detecting the 2.5V power supply	Check connection of Aqua-Sensor to the main board.
Auxiliary Alarm	Auxiliary Input is configured as alarm contacts and was closed for the prescribed amount of time.	Check the device that is connected to the Auxiliary Input.
Brine Blocked	The brine draw rate of water to the brine tank was longer than normal.	Check brine line for blockages or air leaks. Check eductor and eductor screen for blockages
Brine Overfill	Too much water in brine tank. Plugged drain line flow control (Unit will not draw brine). Plugged eductor system (Unit will not draw brine). Slow leak to brine line. Faulty eductor piston. Power outage while control was in refill position.	Check eductor; check for brine draw. Clean drain line flow control. Clean eductor screen and nozzle Replace eductor piston
Call Culligan at xxx-xxx-xxxx	This message is displayed if an error has been detected that requires servicing and no modem installed in the system.	Call the number shown. If possible, place this call using a phone that will allow you to see and enter changes to the main controller if required by the service technician during the call
Check Brine Tank	Aqua-Sensor did not detect brine during the regeneration cycle.	Check brine tank and add salt if necessary. Check Z ratio of the Aqua-Sensor at Main Menu/ Advanced /Diagnostics/ Check Sensors
Check SBT Sensor	SBT sensor indicated improper signals at the beginning of the refill cycle.	The SBT sensor may have an obstruction causing the optical detection paths to all be blocked at once; possible electrical open/short in SBT pcb or wire harness.



Low Battery	Battery needs replacement.	Replace with Panasonic Model# CR 2032 3V battery
Low Salt Level	Salt level is low; less than 15 days of salt remaining.	Contact Culligan dealer for salt delivery or fill brine tank with salt.
Motor Home Err	The controller failed to detect proper position sensor feed back during INITIALIZATION (not during a regen or progressive flow)	Verify that the proper valve type was selected in First Time Setup. Check connections of motor and position sensors at both the motor and the GBE board.
No Refill	Failure to refill brine tank. Refill restrictor plugged. Air in brine line cause float to slam shut.	Clean or replace refill restrictor. Verify all tubing connections are properly assembled.
No Remote Signal	Main board is not receiving a signal from the remote.	Remote is off, out of range or on a different channel from the main board. If interference is suspected, try moving the remote closer or switching to a different channel on both the main and remote units
Pos Sensor Err/ Motor Position Error	The controller is seeking a known valve position before/during/after a regen, or during progressive flow, but cannot find it (this error does NOT appear during initialization).	Check connections of motor and position sensors at both the motor and GBE board.
Replace Ext Filt	Total gallons through the secondary filter (i.e. "Big Blue" filter) has exceeded the specified capacity of the Big Blue.	Replace optional filter cartridge. Reset the external filter media life at Main Menu/ Accessories/ Ext. Filter menu
Salt Bridging	Brine tank has low concentration of brine, but solid salt exists above the liquid brine level.	Use a tool to break up any salt bridge inside the brine tank



## When and How to Bypass Your Water Conditioner

Normally, all water except outside lines passes through the water softener. There are times when the water softener should be bypassed, using the Cul-Flo-Valv® Bypass, or a three-way bypass valve. You should bypass:

1. If lines to outside faucets do not bypass the water softener, and you do not want to waste softened water on lawn sprinkling or other outside uses.
2. If you are going away on vacation and do not want the unit to recharge.

### Bypass Valve

In the back of Culligan water softener is a Cul-Flo-Valv® Bypass valve. To bypass the unit, turn the blue knob clockwise. To return to softened water service, turn the blue knob counter-clockwise.

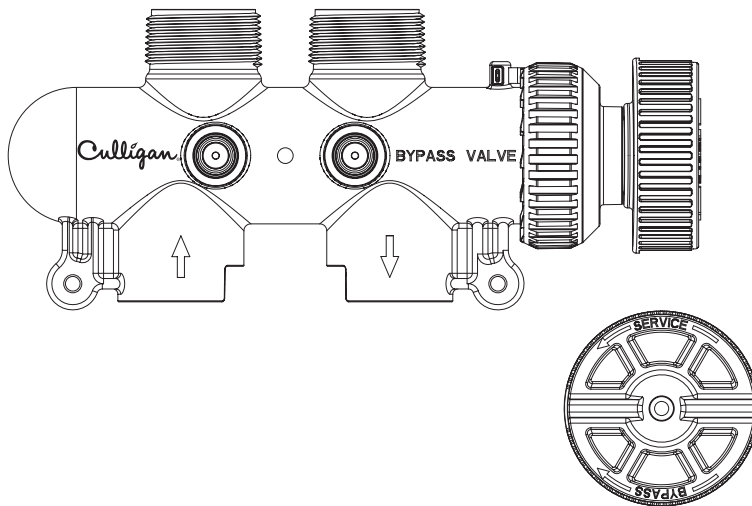

Figure 22. Bypass valve.

### Bypassed

To BYPASS, turn the blue knob clockwise (see directional arrow on end of knob) until the knob stops as shown in Figure 22. DO NOT OVERTIGHTEN!

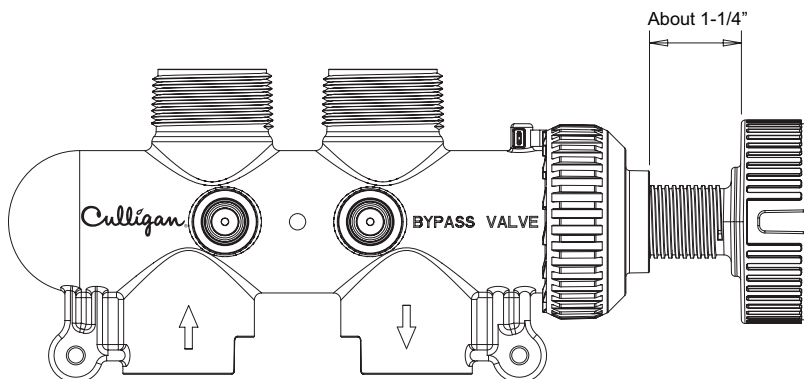

Figure 23. Service valve.

### Softened Water

To return to SERVICE, turn the blue knob counter-clockwise (see directional arrow on end of knob) until the knob stops as shown in Figure 23. DO NOT OVERTIGHTEN!



## Performance Data Sheet

### Culligan High Efficiency 9" Water Softener with Soft-Minder® Meter

Culligan knows the more informed you are about your water treatment systems, the more confident you will be about its performance. It's because of this and more than seventy years of commitment to customer satisfaction that Culligan is providing this Performance Data Sheet to its customers.

**NOTICE** Read this Performance Data Sheet and compare the capabilities of this unit with your actual water treatment needs. It is recommended that before purchasing a water treatment unit, you have your water supply tested to determine your actual water treatment needs.

Manufacturer: Culligan International Company  
9399 W. Higgins Rd., Suite 1100, Rosemont, IL 60018 USA  
(847) 430-2800



Product: Culligan High Efficiency 9" Water Softener with Soft-Minder® Meter

#### Testing Conditions & Results:

Flow Rate:	9.0 gpm @ 11 psi	Capacity:	17,854 grains @ 4.0 lb. salt
Pressure:	30–40 psi (2.1–2.8 kg/cm <sup>2</sup> )		27,108 grains @ 8.0 lb. salt
Acidity:	Non-Corrosive		31,736 grains @ 12.0 lb. salt
Temperature:	68°F (20°C)	pH:	7.6
Efficiency Rated Dosage†:	4,463 gr/lb		

#### Softener Specifications:

Service Flow Rate: 9.0 gpm	Pressure Drop at Max. Flow Rate: 11 psi
Operating Temp. Range: 33–120°F (0–49°C)	Max. Drain Flow Rate: 2.5 gpm
Working Press. Range: 20–125 psi (1.4–8.5 kg/cm <sup>2</sup> )	Oper. Press. Range (Canada): 20–90 psi (1.4–6.3 kg/cm <sup>2</sup> )

Name of Substance	USEPA Max. Contaminant Level	pH	Flow Rate	Pressure
Barium	2.0 mg/L	7.5 + 0.5	9.0 gpm	11 (psig)
Radium 226/228	5 pCi/L	7.5 + 0.5	9.0 gpm	11 (psig)

This system is certified for barium and radium 226/228 reduction based on hardness reduction. It is recommended you test your water every 6 months to ensure the system is performing properly and that hardness, and therefore barium and radium 226/228, are being reduced. Hardness test strips have been included. Additional strips are available from your local Culligan dealer.

The Culligan High Efficiency Series 9" Water Softeners with Soft-Minder® Meter are tested and certified by WQA against NSF/ANSI Standard 372, CSA B483.1, NSF/ANSI Standard 44 for the effective reduction of hardness (calcium and magnesium), barium, and radium 226/228, as verified and substantiated by test data.

An efficiency rated water softener is a DIR softener which also complies with specific performance specifications intended to minimize the amount of regenerant brine and water used in its operation. Efficiency rated water softeners shall have a rated salt efficiency of not less than 3350 grains of total hardness exchange per pound of salt (based on NaCl equivalency) (477 grams of total hardness exchange per kilogram of salt), and shall not deliver more salt than its listed rating. The efficiency is measured by a laboratory test described in NSF/ANSI 44. The test represents the maximum possible efficiency the system can achieve. Operational efficiency is the actual efficiency achieved after the system has been installed. It is typically less than the efficiency due to individual application factors including water hardness, water usage, and other contaminants that reduce the softener's capacity.

Refer to the Specifications, Familiarization and Warranty section of this Owner's Guide for more specific product information. To avoid contamination from improper handling and installation, your system should only be installed and serviced by your Culligan Man. Performance will vary based on local water conditions. The substances reduced by this system are not necessarily in your water.

Culligan water softeners are designed to work with any salt of good quality, although it is recommended that you ask your local Culligan Man for his suggestion on the best type and grade of salt to use in this softener.

**NOTICE** This softener is not intended to be used for treating water that is microbiologically unsafe or of unknown quality without adequate disinfection before or after the system.

†The efficiency rated dosage is only valid at the 4lb. salt dosage and maximum service flow rate for 9" models.



## Performance Data Sheet

### Culligan High Efficiency 9" Water Softener with Aqua-Sensor® Sensing Device

Culligan knows the more informed you are about your water treatment systems, the more confident you will be about its performance. It's because of this and more than seventy years of commitment to customer satisfaction that Culligan is providing this Performance Data Sheet to its customers.

**NOTICE** Read this Performance Data Sheet and compare the capabilities of this unit with your actual water treatment needs. It is recommended that before purchasing a water treatment unit, you have your water supply tested to determine your actual water treatment needs.

Manufacturer: Culligan International Company  
9399 W. Higgins Rd., Suite 1100, Rosemont, IL 60018 USA  
(847) 430-2800



Product: Culligan High Efficiency 9" Water Softener with Aqua-Sensor® Sensing Device

#### Testing Conditions & Results:

Flow Rate:	9.0 gpm @ 11 psi	Capacity:	17,854 grains @ 4.0 lb. salt
Pressure:	30–40 psi (2.1–2.8 kg/cm <sup>2</sup> )		27,108 grains @ 8.0 lb. salt
Acidity:	Non-Corrosive		31,736 grains @ 12.0 lb. salt
Temperature:	68°F (20°C)	pH:	7.6
Efficiency Rated Dosage†:	4,463 gr/lb		

#### Softener Specifications:

Service Flow Rate: 9.0 gpm	Pressure Drop at Max. Flow Rate: 11 psi
Operating Temp. Range: 33–120°F (0–49°C)	Max. Drain Flow Rate: 2.5 gpm
Working Press. Range: 20–125 psi (1.4–8.5 kg/cm <sup>2</sup> )	Oper. Press. Range (Canada): 20–90 psi (1.4–6.3 kg/cm <sup>2</sup> )

Name of Substance	USEPA Max. Contaminant Level	pH	Flow Rate	Pressure
Barium	2.0 mg/L	7.5 + 0.5	9.0 gpm	11 (psig)
Radium 226/228	5 pCi/L	7.5 + 0.5	9.0 gpm	11 (psig)

This system is certified for barium and radium 226/228 reduction based on hardness reduction. It is recommended you test your water every 6 months to ensure the system is performing properly and that hardness, and therefore barium and radium 226/228, are being reduced. Hardness test strips have been included. Additional strips are available from your local Culligan dealer.

The Culligan High Efficiency 9" Water Softeners with Aqua-Sensor® Sensing Device are tested and certified by WQA against NSF/ANSI Standard 372, CSA B483.1, NSF/ANSI Standard 44 for the effective reduction of hardness (calcium and magnesium), barium, and radium 226/228, as verified and substantiated by test data.

An efficiency rated water softener is a DIR softener which also complies with specific performance specifications intended to minimize the amount of regenerant brine and water used in its operation. Efficiency rated water softeners shall have a rated salt efficiency of not less than 3350 grains of total hardness exchange per pound of salt (based on NaCl equivalency) (477 grams of total hardness exchange per kilogram of salt), and shall not deliver more salt than its listed rating. The efficiency is measured by a laboratory test described in NSF/ANSI 44. The test represents the maximum possible efficiency the system can achieve. Operational efficiency is the actual efficiency achieved after the system has been installed. It is typically less than the efficiency due to individual application factors including water hardness, water usage, and other contaminants that reduce the softener's capacity.

Refer to the Specifications, Familiarization and Warranty section of this Owner's Guide for more specific product information. To avoid contamination from improper handling and installation, your system should only be installed and serviced by your Culligan Man. Performance will vary based on local water conditions. The substances reduced by this system are not necessarily in your water.

Culligan water softeners are designed to work with any salt of good quality, although it is recommended that you ask your local Culligan Man for his suggestion on the best type and grade of salt to use in this softener.

**NOTICE** This softener is not intended to be used for treating water that is microbiologically unsafe or of unknown quality without adequate disinfection before or after the system.

†The efficiency rated dosage is only valid at the 4lb. salt dosage and maximum service flow rate for 9" models.



## Performance Data Sheet

### Culligan High Efficiency 10" Water Softener with Soft-Minder® Meter

Culligan knows the more informed you are about your water treatment systems, the more confident you will be about its performance. It's because of this and more than seventy years of commitment to customer satisfaction that Culligan is providing this Performance Data Sheet to its customers.

**NOTICE** Read this Performance Data Sheet and compare the capabilities of this unit with your actual water treatment needs. It is recommended that before purchasing a water treatment unit, you have your water supply tested to determine your actual water treatment needs.

Manufacturer: Culligan International Company  
 9399 W. Higgins Rd., Suite 1100, Rosemont, IL 60018 USA  
 (847) 430-2800



Product: Culligan High Efficiency 10" Water Softener with Soft-Minder® Meter

#### Testing Conditions & Results:

Flow Rate:	9.4 gpm @ 12 psi	Capacity:	26,781 grains @ 6.0 lb. salt
Pressure:	30–40 psi (2.1–2.8 kg/cm <sup>2</sup> )		40,662 grains @ 12.0 lb. salt
Acidity:	Non-Corrosive		47,604 grains @ 18.0 lb. salt
Temperature:	68°F (20°C)	pH:	7.6
Efficiency Rated Dosage†:	4,463 gr/lb		

#### Softener Specifications:

Service Flow Rate: 9.4 gpm	Pressure Drop at Max. Flow Rate: 12 psi
Operating Temp. Range: 33–120°F (0–49°C)	Max. Drain Flow Rate: 2.0 gpm
Working Press. Range: 20–125 psi (1.4–8.5 kg/cm <sup>2</sup> )	Oper. Press. Range (Canada): 20–90 psi (1.4–6.3 kg/cm <sup>2</sup> )

Name of Substance	USEPA Max. Contaminant Level	pH	Flow Rate	Pressure
Barium	2.0 mg/L	7.5 + 0.5	9.4 gpm	12 (psig)
Radium 226/228	5 pCi/L	7.5 + 0.5	9.4 gpm	12 (psig)

This system is certified for barium and radium 226/228 reduction based on hardness reduction. It is recommended you test your water every 6 months to ensure the system is performing properly and that hardness, and therefore barium and radium 226/228, are being reduced. Hardness test strips have been included. Additional strips are available from your local Culligan dealer.

The Culligan High Efficiency Series 10" Water Softeners with Soft-Minder® Meter are tested and certified by WQA against NSF/ANSI Standard 372, CSA B483.1, NSF/ANSI Standard 44 for the effective reduction of hardness (calcium and magnesium), barium, and radium 226/228, as verified and substantiated by test data.

An efficiency rated water softener is a DIR softener which also complies with specific performance specifications intended to minimize the amount of regenerant brine and water used in its operation. Efficiency rated water softeners shall have a rated salt efficiency of not less than 3350 grains of total hardness exchange per pound of salt (based on NaCl equivalency) (477 grams of total hardness exchange per kilogram of salt), and shall not deliver more salt than its listed rating. The efficiency is measured by a laboratory test described in NSF/ANSI 44. The test represents the maximum possible efficiency the system can achieve. Operational efficiency is the actual efficiency achieved after the system has been installed. It is typically less than the efficiency due to individual application factors including water hardness, water usage, and other contaminants that reduce the softener's capacity.

Refer to the Specifications, Familiarization and Warranty section of this Owner's Guide for more specific product information. To avoid contamination from improper handling and installation, your system should only be installed and serviced by your Culligan Man. Performance will vary based on local water conditions. The substances reduced by this system are not necessarily in your water.

Culligan water softeners are designed to work with any salt of good quality, although it is recommended that you ask your local Culligan Man for his suggestion on the best type and grade of salt to use in this softener.

**NOTICE** This softener is not intended to be used for treating water that is microbiologically unsafe or of unknown quality without adequate disinfection before or after the system.

†The efficiency rated dosage is only valid at the 6 lb. salt dosage and maximum service flow rate for 10" models.



## Performance Data Sheet

### Culligan High Efficiency 10" Water Softener with Aqua-Sensor® Sensing Device

Culligan knows the more informed you are about your water treatment systems, the more confident you will be about its performance. It's because of this and more than seventy years of commitment to customer satisfaction that Culligan is providing this Performance Data Sheet to its customers.

**NOTICE** Read this Performance Data Sheet and compare the capabilities of this unit with your actual water treatment needs. It is recommended that before purchasing a water treatment unit, you have your water supply tested to determine your actual water treatment needs.

Manufacturer: Culligan International Company  
9399 W. Higgins Rd., Suite 1100, Rosemont, IL 60018 USA  
(847) 430-2800

Product: Culligan High Efficiency 10" Water Softener with Aqua-Sensor® Sensing Device



#### Testing Conditions & Results:

Flow Rate:	9.4 gpm @ 12 psi	Capacity:	26,781 grains @ 6.0 lb. salt
Pressure:	30–40 psi (2.1–2.8 kg/cm <sup>2</sup> )		40,662 grains @ 12.0 lb. salt
Acidity:	Non-Corrosive		47,604 grains @ 18.0 lb. salt
Temperature:	68°F (20°C)	pH:	7.6
Efficiency Rated Dosage†:	4,463 gr/lb		

#### Softener Specifications:

Service Flow Rate: 9.4 gpm	Pressure Drop at Max. Flow Rate: 12 psi
Operating Temp. Range: 33–120°F (0–49°C)	Max. Drain Flow Rate: 2.0 gpm
Working Press. Range: 20–125 psi (1.4–8.5 kg/cm <sup>2</sup> )	Oper. Press. Range (Canada): 20–90 psi (1.4–6.3 kg/cm <sup>2</sup> )

Name of Substance	USEPA Max. Contaminant Level	pH	Flow Rate	Pressure
Barium	2.0 mg/L	7.5 + 0.5	9.4 gpm	12 (psig)
Radium 226/228	5 pCi/L	7.5 + 0.5	9.4 gpm	12 (psig)

This system is certified for barium and radium 226/228 reduction based on hardness reduction. It is recommended you test your water every 6 months to ensure the system is performing properly and that hardness, and therefore barium and radium 226/228, are being reduced. Hardness test strips have been included. Additional strips are available from your local Culligan dealer.

The Culligan High Efficiency 10" Water Softeners with Aqua-Sensor® Sensing Device are tested and certified by WQA against NSF/ANSI Standard 372, CSA B483.1, NSF/ANSI Standard 44 for the effective reduction of hardness (calcium and magnesium), barium, and radium 226/228, as verified and substantiated by test data.

An efficiency rated water softener is a DIR softener which also complies with specific performance specifications intended to minimize the amount of regenerant brine and water used in its operation. Efficiency rated water softeners shall have a rated salt efficiency of not less than 3350 grains of total hardness exchange per pound of salt (based on NaCl equivalency) (477 grams of total hardness exchange per kilogram of salt), and shall not deliver more salt than its listed rating. The efficiency is measured by a laboratory test described in NSF/ANSI 44. The test represents the maximum possible efficiency the system can achieve. Operational efficiency is the actual efficiency achieved after the system has been installed. It is typically less than the efficiency due to individual application factors including water hardness, water usage, and other contaminants that reduce the softener's capacity.

Refer to the Specifications, Familiarization and Warranty section of this Owner's Guide for more specific product information. To avoid contamination from improper handling and installation, your system should only be installed and serviced by your Culligan Man. Performance will vary based on local water conditions. The substances reduced by this system are not necessarily in your water.

Culligan water softeners are designed to work with any salt of good quality, although it is recommended that you ask your local Culligan Man for his suggestion on the best type and grade of salt to use in this softener.

**NOTICE** This softener is not intended to be used for treating water that is microbiologically unsafe or of unknown quality without adequate disinfection before or after the system.

†The efficiency rated dosage is only valid at the 6lb. salt dosage and maximum service flow rate for 10" models.



## Performance Data Sheet

### Culligan High Efficiency 12" Water Softener with Soft-Minder® Meter

Culligan knows the more informed you are about your water treatment systems, the more confident you will be about its performance. It's because of this and more than seventy years of commitment to customer satisfaction that Culligan is providing this Performance Data Sheet to its customers.

**NOTICE** Read this Performance Data Sheet and compare the capabilities of this unit with your actual water treatment needs. It is recommended that before purchasing a water treatment unit, you have your water supply tested to determine your actual water treatment needs.

Manufacturer: Culligan International Company  
 9399 W. Higgins Rd., Suite 1100, Rosemont, IL 60018 USA  
 (847) 430-2800



Product: Culligan High Efficiency 12" Water Softener with Soft-Minder® Meter

#### Testing Conditions & Results:

Flow Rate:	10.0 gpm @ 10 psi	Capacity:	31,352 grains @ 7.0 lb. salt
Pressure:	30–40 psi (2.1–2.8 kg/cm <sup>2</sup> )		48,458 grains @ 16.0 lb. salt
Acidity:	Non-Corrosive		59,267 grains @ 24.0 lb. salt
Temperature:	68°F (20°C)	pH:	7.6
Efficiency Rated Dosage†:	4,479 gr/lb		

#### Softener Specifications:

Service Flow Rate: 10.0 gpm	Pressure Drop at Max. Flow Rate: 10 psi (71 kPa)
Operating Temp. Range: 33–120°F (0–49°C)	Max. Drain Flow Rate: 3.0 gpm
Working Press. Range: 20–125 psi (1.4–8.5 kg/cm <sup>2</sup> )	Oper. Press. Range (Canada): 20–90 psi (1.4–6.3 kg/cm <sup>2</sup> )

Name of Substance	USEPA Max. Contaminant Level	pH	Flow Rate	Pressure
Barium	2.0 mg/L	7.5 + 0.5	10.0 gpm	10 (psig)
Radium 226/228	5 pCi/L	7.5 + 0.5	10.0 gpm	10 (psig)

This system is certified for barium and radium 226/228 reduction based on hardness reduction. It is recommended you test your water every 6 months to ensure the system is performing properly and that hardness, and therefore barium and radium 226/228, are being reduced. Hardness test strips have been included. Additional strips are available from your local Culligan dealer.

The Culligan High Efficiency Series 12" Water Softeners with Soft-Minder® Meter are tested and certified by WQA against NSF/ANSI Standard 372, CSA B483.1, NSF/ANSI Standard 44 for the effective reduction of hardness (calcium and magnesium), barium, and radium 226/228, as verified and substantiated by test data.

An efficiency rated water softener is a DIR softener which also complies with specific performance specifications intended to minimize the amount of regenerant brine and water used in its operation. Efficiency rated water softeners shall have a rated salt efficiency of not less than 3350 grains of total hardness exchange per pound of salt (based on NaCl equivalency) (477 grams of total hardness exchange per kilogram of salt), and shall not deliver more salt than its listed rating. The efficiency is measured by a laboratory test described in NSF/ANSI 44. The test represents the maximum possible efficiency the system can achieve. Operational efficiency is the actual efficiency achieved after the system has been installed. It is typically less than the efficiency due to individual application factors including water hardness, water usage, and other contaminants that reduce the softener's capacity.

Refer to the Specifications, Familiarization and Warranty section of this Owner's Guide for more specific product information. To avoid contamination from improper handling and installation, your system should only be installed and serviced by your Culligan Man. Performance will vary based on local water conditions. The substances reduced by this system are not necessarily in your water.

Culligan water softeners are designed to work with any salt of good quality, although it is recommended that you ask your local Culligan Man for his suggestion on the best type and grade of salt to use in this softener.

**NOTICE** This softener is not intended to be used for treating water that is microbiologically unsafe or of unknown quality without adequate disinfection before or after the system.

†The efficiency rated dosage is only valid at the 8 lb. salt dosage and maximum service flow rate for 12" models.





## Performance Data Sheet

### Culligan High Efficiency 12" Water Softener with Aqua-Sensor® Sensing Device

Culligan knows the more informed you are about your water treatment systems, the more confident you will be about its performance. It's because of this and more than seventy years of commitment to customer satisfaction that Culligan is providing this Performance Data Sheet to its customers.

**NOTICE** Read this Performance Data Sheet and compare the capabilities of this unit with your actual water treatment needs. It is recommended that before purchasing a water treatment unit, you have your water supply tested to determine your actual water treatment needs.

Manufacturer: Culligan International Company  
9399 W. Higgins Rd., Suite 1100, Rosemont, IL 60018 USA  
(847) 430-2800



Product: Culligan High Efficiency 12" Water Softener with Aqua-Sensor® Sensing Device

#### Testing Conditions & Results:

Flow Rate:	10.0 gpm @ 10 psi	Capacity:	31,352 grains @ 7.0 lb. salt
Pressure:	30–40 psi (2.1–2.8 kg/cm <sup>2</sup> )		48,458 grains @ 16.0 lb. salt
Acidity:	Non-Corrosive		59,267 grains @ 24.0 lb. salt
Temperature:	68°F (20°C)	pH:	7.6
Efficiency Rated Dosage†:	4,479 gr/lb		

#### Softener Specifications:

Service Flow Rate: 10.0 gpm	Pressure Drop at Max. Flow Rate: 10 psi (71 kPa)
Operating Temp. Range: 33–120°F (0–49°C)	Max. Drain Flow Rate: 3.0 gpm
Working Press. Range: 20–125 psi (1.4–8.5 kg/cm <sup>2</sup> )	Oper. Press. Range (Canada): 20–90 psi (1.4–6.3 kg/cm <sup>2</sup> )

Name of Substance	USEPA Max. Contaminant Level	pH	Flow Rate	Pressure
Barium	2.0 mg/L	7.5 + 0.5	10.0 gpm	10 (psig)
Radium 226/228	5 pCi/L	7.5 + 0.5	10.0 gpm	10 (psig)

This system is certified for barium and radium 226/228 reduction based on hardness reduction. It is recommended you test your water every 6 months to ensure the system is performing properly and that hardness, and therefore barium and radium 226/228, are being reduced. Hardness test strips have been included. Additional strips are available from your local Culligan dealer.

The Culligan High Efficiency 12" Water Softeners with Aqua-Sensor® Sensing Device are tested and certified by WQA against NSF/ANSI Standard 372, CSA B483.1, NSF/ANSI Standard 44 for the effective reduction of hardness (calcium and magnesium), barium, and radium 226/228, as verified and substantiated by test data.

An efficiency rated water softener is a DIR softener which also complies with specific performance specifications intended to minimize the amount of regenerant brine and water used in its operation. Efficiency rated water softeners shall have a rated salt efficiency of not less than 3350 grains of total hardness exchange per pound of salt (based on NaCl equivalency) (477 grams of total hardness exchange per kilogram of salt), and shall not deliver more salt than its listed rating. The efficiency is measured by a laboratory test described in NSF/ANSI 44. The test represents the maximum possible efficiency the system can achieve. Operational efficiency is the actual efficiency achieved after the system has been installed. It is typically less than the efficiency due to individual application factors including water hardness, water usage, and other contaminants that reduce the softener's capacity.

Refer to the Specifications, Familiarization and Warranty section of this Owner's Guide for more specific product information. To avoid contamination from improper handling and installation, your system should only be installed and serviced by your Culligan Man. Performance will vary based on local water conditions. The substances reduced by this system are not necessarily in your water.

Culligan water softeners are designed to work with any salt of good quality, although it is recommended that you ask your local Culligan Man for his suggestion on the best type and grade of salt to use in this softener.

**NOTICE** This softener is not intended to be used for treating water that is microbiologically unsafe or of unknown quality without adequate disinfection before or after the system.

†The efficiency rated dosage is only valid at the 8 lb. salt dosage and maximum service flow rate for 12" models.



## Performance Data Sheet

### Culligan High Efficiency 14" Water Softener with Soft-Minder® Meter

Culligan knows the more informed you are about your water treatment systems, the more confident you will be about its performance. It's because of this and more than seventy years of commitment to customer satisfaction that Culligan is providing this Performance Data Sheet to its customers.

**NOTICE** Read this Performance Data Sheet and compare the capabilities of this unit with your actual water treatment needs. It is recommended that before purchasing a water treatment unit, you have your water supply tested to determine your actual water treatment needs.

Manufacturer: Culligan International Company  
 9399 W. Higgins Rd., Suite 1100, Rosemont, IL 60018 USA  
 (847) 430-2800



C USA

Product: Culligan High Efficiency 14" Water Softener with Soft-Minder® Meter

#### Testing Conditions & Results:

Flow Rate:	10.6 gpm @ 11 psi	Capacity:	51,726 grains @ 12.0 lb. salt
Pressure:	30–40 psi (2.1–2.8 kg/cm <sup>2</sup> )		75,582 grains @ 24.0 lb. salt
Acidity:	Non-Corrosive		88,549 grains @ 36.0 lb. salt
Temperature:	68°F (20°C)	pH:	7.6
Efficiency Rated Dosage†:	4,310 gr/lb		

#### Softener Specifications:

Service Flow Rate: 10.6 gpm	Pressure Drop at Max. Flow Rate: 11 psi
Operating Temp. Range: 33–120°F (0–49°C)	Max. Drain Flow Rate: 2.5 gpm
Working Press. Range: 20–125 psi (1.4–8.5 kg/cm <sup>2</sup> )	Oper. Press. Range (Canada): 20–90 psi (1.4–6.3 kg/cm <sup>2</sup> )

Name of Substance	USEPA Max. Contaminant Level	pH	Flow Rate	Pressure
Barium	2.0 mg/L	7.5 + 0.5	10.6 gpm	11 (psig)
Radium 226/228	5 pCi/L	7.5 + 0.5	10.6 gpm	11 (psig)

This system is certified for barium and radium 226/228 reduction based on hardness reduction. It is recommended you test your water every 6 months to ensure the system is performing properly and that hardness, and therefore barium and radium 226/228, are being reduced. Hardness test strips have been included. Additional strips are available from your local Culligan dealer.

The Culligan High Efficiency Series 14" Water Softeners with Soft-Minder® Meter are tested and certified by WQA against NSF/ANSI Standard 372, CSA B483.1, NSF/ANSI Standard 44 for the effective reduction of hardness (calcium and magnesium), barium, and radium 226/228, as verified and substantiated by test data.

An efficiency rated water softener is a DIR softener which also complies with specific performance specifications intended to minimize the amount of regenerant brine and water used in its operation. Efficiency rated water softeners shall have a rated salt efficiency of not less than 3350 grains of total hardness exchange per pound of salt (based on NaCl equivalency) (477 grams of total hardness exchange per kilogram of salt), and shall not deliver more salt than its listed rating. The efficiency is measured by a laboratory test described in NSF/ANSI 44. The test represents the maximum possible efficiency the system can achieve. Operational efficiency is the actual efficiency achieved after the system has been installed. It is typically less than the efficiency due to individual application factors including water hardness, water usage, and other contaminants that reduce the softener's capacity.

Refer to the Specifications, Familiarization and Warranty section of this Owner's Guide for more specific product information. To avoid contamination from improper handling and installation, your system should only be installed and serviced by your Culligan Man. Performance will vary based on local water conditions. The substances reduced by this system are not necessarily in your water.

Culligan water softeners are designed to work with any salt of good quality, although it is recommended that you ask your local Culligan Man for his suggestion on the best type and grade of salt to use in this softener.

**NOTICE** This softener is not intended to be used for treating water that is microbiologically unsafe or of unknown quality without adequate disinfection before or after the system.

†The efficiency rated dosage is only valid at the 12 lb. salt dosage and maximum service flow rate for 14" models.



## Performance Data Sheet

### Culligan High Efficiency 14" Water Softener with Aqua-Sensor® Sensing Device

Culligan knows the more informed you are about your water treatment systems, the more confident you will be about its performance. It's because of this and more than seventy years of commitment to customer satisfaction that Culligan is providing this Performance Data Sheet to its customers.

**NOTICE** Read this Performance Data Sheet and compare the capabilities of this unit with your actual water treatment needs. It is recommended that before purchasing a water treatment unit, you have your water supply tested to determine your actual water treatment needs.

Manufacturer: Culligan International Company  
9399 W. Higgins Rd., Suite 1100, Rosemont, IL 60018 USA  
(847) 430-2800



Product: Culligan High Efficiency 14" Water Softener with Aqua-Sensor® Sensing Device

#### Testing Conditions & Results:

Flow Rate:	10.6 gpm @ 11 psi	Capacity:	51,726 grains @ 12.0 lb. salt
Pressure:	30–40 psi (2.1–2.8 kg/cm <sup>2</sup> )		75,582 grains @ 24.0 lb. salt
Acidity:	Non-Corrosive		88,549 grains @ 36.0 lb. salt
Temperature:	68°F (20°C)	pH:	7.6
Efficiency Rated Dosage†:	4,310 gr/lb		

#### Softener Specifications:

Service Flow Rate:	10.6 gpm	Pressure Drop at Max. Flow Rate:	11 psi
Operating Temp. Range:	33–120°F (0–49°C)	Max. Drain Flow Rate:	2.5 gpm
Working Press. Range:	20–125 psi (1.4–8.5 kg/cm <sup>2</sup> )	Oper. Press. Range (Canada):	20–90 psi (1.4–6.3 kg/cm <sup>2</sup> )

Name of Substance	USEPA Max. Contaminant Level	pH	Flow Rate	Pressure
Barium	2.0 mg/L	7.5 + 0.5	10.6 gpm	11 (psig)
Radium 226/228	5 pCi/L	7.5 + 0.5	10.6 gpm	11 (psig)

This system is certified for barium and radium 226/228 reduction based on hardness reduction. It is recommended you test your water every 6 months to ensure the system is performing properly and that hardness, and therefore barium and radium 226/228, are being reduced. Hardness test strips have been included. Additional strips are available from your local Culligan dealer.

The Culligan High Efficiency 14" Water Softeners with Aqua-Sensor® Sensing Device are tested and certified by WQA against NSF/ANSI Standard 372, CSA B483.1, NSF/ANSI Standard 44 for the effective reduction of hardness (calcium and magnesium), barium, and radium 226/228, as verified and substantiated by test data.

An efficiency rated water softener is a DIR softener which also complies with specific performance specifications intended to minimize the amount of regenerant brine and water used in its operation. Efficiency rated water softeners shall have a rated salt efficiency of not less than 3350 grains of total hardness exchange per pound of salt (based on NaCl equivalency) (477 grams of total hardness exchange per kilogram of salt), and shall not deliver more salt than its listed rating. The efficiency is measured by a laboratory test described in NSF/ANSI 44. The test represents the maximum possible efficiency the system can achieve. Operational efficiency is the actual efficiency achieved after the system has been installed. It is typically less than the efficiency due to individual application factors including water hardness, water usage, and other contaminants that reduce the softener's capacity.

Refer to the Specifications, Familiarization and Warranty section of this Owner's Guide for more specific product information. To avoid contamination from improper handling and installation, your system should only be installed and serviced by your Culligan Man. Performance will vary based on local water conditions. The substances reduced by this system are not necessarily in your water.

Culligan water softeners are designed to work with any salt of good quality, although it is recommended that you ask your local Culligan Man for his suggestion on the best type and grade of salt to use in this softener.

**NOTICE** This softener is not intended to be used for treating water that is microbiologically unsafe or of unknown quality without adequate disinfection before or after the system.

†The efficiency rated dosage is only valid at the 12lb. salt dosage and maximum service flow rate for 14" models.



## Performance Data Sheet

### Culligan High Efficiency 9" Upflow Water Softener with Soft-Minder® Meter

Culligan knows the more informed you are about your water treatment systems, the more confident you will be about its performance. It's because of this and more than seventy years of commitment to customer satisfaction that Culligan is providing this Performance Data Sheet to its customers.

**NOTICE** Read this Performance Data Sheet and compare the capabilities of this unit with your actual water treatment needs. It is recommended that before purchasing a water treatment unit, you have your water supply tested to determine your actual water treatment needs.

Manufacturer: Culligan International Company  
9399 W. Higgins Rd., Suite 1100, Rosemont, IL 60018 USA  
(847) 430-2800

Product: Culligan High Efficiency 9" Upflow Water Softener with Soft-Minder® Meter



#### Testing Conditions & Results:

Flow Rate:	9.0 gpm @ 11 psi	Capacity:	9,792 grains @ 2.0 lb. salt
Pressure:	30–40 psi (2.1–2.8 kg/cm <sup>2</sup> )		17,366 grains @ 4.0 lb. salt
Acidity:	Non-Corrosive		27,306 grains @ 8.0 lb. salt
Temperature:	68°F (20°C)		
Efficiency Rated Dosage†:	4,896 gr/lb	pH:	7.6

#### Softener Specifications:

Service Flow Rate: 9.0 gpm	Pressure Drop at Max. Flow Rate: 11 psi
Operating Temp. Range: 33–120°F (0–49°C)	Max. Drain Flow Rate: 2.2 gpm
Working Press. Range: 20–125 psi (1.4–8.5 kg/cm <sup>2</sup> )	Oper. Press. Range (Canada): 20–90 psi (1.4–6.3 kg/cm <sup>2</sup> )

Name of Substance	USEPA Max. Contaminant Level	pH	Flow Rate	Pressure
Barium	2.0 mg/L	7.5 + 0.5	9.0 gpm	11 (psig)
Radium 226/228	5 pCi/L	7.5 + 0.5	9.0 gpm	11 (psig)

This system is certified for barium and radium 226/228 reduction based on hardness reduction. It is recommended you test your water every six months to ensure the system is performing properly and that hardness, and therefore barium and radium 226/228, are being reduced. Hardness test strips have been included. Additional strips are available from your local Culligan dealer.

The Culligan High Efficiency Series 9" Upflow Water Softeners with Soft-Minder® Meter are tested and certified by WQA against NSF/ANSI Standard 372, CSA B483.1, NSF/ANSI Standard 44 for the effective reduction of hardness (calcium and magnesium), barium, and radium 226/228, as verified and substantiated by test data.

An efficiency rated water softener is a DIR softener which also complies with specific performance specifications intended to minimize the amount of regenerant brine and water used in its operation. Efficiency rated water softeners shall have a rated salt efficiency of not less than 3350 grains of total hardness exchange per pound of salt (based on NaCl equivalency) (477 grams of total hardness exchange per kilogram of salt), and shall not deliver more salt than its listed rating. The efficiency is measured by a laboratory test described in NSF/ANSI 44. The test represents the maximum possible efficiency the system can achieve. Operational efficiency is the actual efficiency achieved after the system has been installed. It is typically less than the efficiency due to individual application factors including water hardness, water usage, and other contaminants that reduce the softener's capacity.

Refer to the Specifications, Familiarization and Warranty section of this Owner's Guide for more specific product information. To avoid contamination from improper handling and installation, your system should only be installed and serviced by your Culligan Man. Performance will vary based on local water conditions. The substances reduced by this system are not necessarily in your water.

Culligan water softeners are designed to work with any salt of good quality, although it is recommended that you ask your local Culligan Man for his suggestion on the best type and grade of salt to use in this softener.

**NOTICE** This softener is not intended to be used for treating water that is microbiologically unsafe or of unknown quality without adequate disinfection before or after the system.

†The efficiency rated dosage is only valid at the 2 lb. salt dosage and maximum service flow rate for 9" models.



## Performance Data Sheet

### Culligan High Efficiency 9" Upflow Water Softener with Aqua-Sensor® Sensing Device

Culligan knows the more informed you are about your water treatment systems, the more confident you will be about its performance. It's because of this and more than seventy years of commitment to customer satisfaction that Culligan is providing this Performance Data Sheet to its customers.

**NOTICE** Read this Performance Data Sheet and compare the capabilities of this unit with your actual water treatment needs. It is recommended that before purchasing a water treatment unit, you have your water supply tested to determine your actual water treatment needs.

Manufacturer: Culligan International Company  
9399 W. Higgins Rd., Suite 1100, Rosemont, IL 60018 USA  
(847) 430-2800



Product: Culligan High Efficiency 9" Upflow Water Softener with Aqua-Sensor® Sensing Device

#### Testing Conditions & Results:

Flow Rate:	9.0 gpm @ 11 psi	Capacity:	9,792 grains @ 2.0 lb. salt
Pressure:	30–40 psi (2.1–2.8 kg/cm <sup>2</sup> )		17,366 grains @ 4.0 lb. salt
Acidity:	Non-Corrosive		27,306 grains @ 8.0 lb. salt
Temperature:	68°F (20°C)		
Efficiency Rated Dosage†:	4,896 gr/lb	pH:	7.6

#### Softener Specifications:

Service Flow Rate: 9.0 gpm	Pressure Drop at Max. Flow Rate: 11 psi
Operating Temp. Range: 33–120°F (0–49°C)	Max. Drain Flow Rate: 2.5 gpm
Working Press. Range: 20–125 psi (1.4–8.5 kg/cm <sup>2</sup> )	Oper. Press. Range (Canada): 20–90 psi (1.4–6.3 kg/cm <sup>2</sup> )

Name of Substance	USEPA Max. Contaminant Level	pH	Flow Rate	Pressure
Barium	2.0 mg/L	7.5 + 0.5	9.0 gpm	11 (psig)
Radium 226/228	5 pCi/L	7.5 + 0.5	9.0 gpm	11 (psig)

This system is certified for barium and radium 226/228 reduction based on hardness reduction. It is recommended you test your water every six months to ensure the system is performing properly and that hardness, and therefore barium and radium 226/228, are being reduced. Hardness test strips have been included. Additional strips are available from your local Culligan dealer.

The Culligan High Efficiency 9" Upflow Water Softeners with Aqua-Sensor® Sensing Device are tested and certified by WQA against NSF/ANSI Standard 372, CSA B483.1, NSF/ANSI Standard 44 for the effective reduction of hardness (calcium and magnesium), barium, and radium 226/228, as verified and substantiated by test data.

An efficiency rated water softener is a DIR softener which also complies with specific performance specifications intended to minimize the amount of regenerant brine and water used in its operation. Efficiency rated water softeners shall have a rated salt efficiency of not less than 3350 grains of total hardness exchange per pound of salt (based on NaCl equivalency) (477 grams of total hardness exchange per kilogram of salt), and shall not deliver more salt than its listed rating. The efficiency is measured by a laboratory test described in NSF/ANSI 44. The test represents the maximum possible efficiency the system can achieve. Operational efficiency is the actual efficiency achieved after the system has been installed. It is typically less than the efficiency due to individual application factors including water hardness, water usage, and other contaminants that reduce the softener's capacity.

Refer to the Specifications, Familiarization and Warranty section of this Owner's Guide for more specific product information. To avoid contamination from improper handling and installation, your system should only be installed and serviced by your Culligan Man. Performance will vary based on local water conditions. The substances reduced by this system are not necessarily in your water.

Culligan water softeners are designed to work with any salt of good quality, although it is recommended that you ask your local Culligan Man for his suggestion on the best type and grade of salt to use in this softener.

**NOTICE** This softener is not intended to be used for treating water that is microbiologically unsafe or of unknown quality without adequate disinfection before or after the system.

†The efficiency rated dosage is only valid at the 2 lb. salt dosage and maximum service flow rate for 9" models.



## Performance Data Sheet

### Culligan High Efficiency 10" Upflow Water Softener with Soft-Minder® Meter

Culligan knows the more informed you are about your water treatment systems, the more confident you will be about its performance. It's because of this and more than seventy years of commitment to customer satisfaction that Culligan is providing this Performance Data Sheet to its customers.

**NOTICE** Read this Performance Data Sheet and compare the capabilities of this unit with your actual water treatment needs. It is recommended that before purchasing a water treatment unit, you have your water supply tested to determine your actual water treatment needs.

Manufacturer: Culligan International Company  
9399 W. Higgins Rd., Suite 1100, Rosemont, IL 60018 USA  
(847) 430-2800



Product: Culligan High Efficiency 10" Upflow Water Softener with Soft-Minder® Meter

#### Testing Conditions & Results:

Flow Rate:	9.4 gpm @ 12 psi	Capacity:	30,081 grains @ 6.0 lb. salt
Pressure:	30–40 psi (2.1–2.8 kg/cm <sup>2</sup> )		47,726 grains @ 12.0 lb. salt
Acidity:	Non-Corrosive		54,975 grains @ 18.0 lb. salt
Temperature:	68°F (20°C)	pH:	7.6
Efficiency Rated Dosage†:	5,014 gr/lb		

#### Softener Specifications:

Service Flow Rate: 9.4 gpm	Pressure Drop at Max. Flow Rate: 12 psi
Operating Temp. Range: 33–120°F (0–49°C)	Max. Drain Flow Rate: 2.3 gpm
Working Press. Range: 20–125 psi (1.4–8.5 kg/cm <sup>2</sup> )	Oper. Press. Range (Canada): 20–90 psi (1.4–6.3 kg/cm <sup>2</sup> )

Name of Substance	USEPA Max. Contaminant Level	pH	Flow Rate	Pressure
Barium	2.0 mg/L	7.5 + 0.5	9.4 gpm	12 (psig)
Radium 226/228	5 pCi/L	7.5 + 0.5	9.4 gpm	12 (psig)

This system is certified for barium and radium 226/228 reduction based on hardness reduction. It is recommended you test your water every six months to ensure the system is performing properly and that hardness, and therefore barium and radium 226/228, are being reduced. Hardness test strips have been included. Additional strips are available from your local Culligan dealer.

The Culligan High Efficiency Series 10" Upflow Water Softeners with Soft-Minder® Meter are tested and certified by WQA against NSF/ANSI Standard 372, CSA B483.1, NSF/ANSI Standard 44 for the effective reduction of hardness (calcium and magnesium), barium, and radium 226/228, as verified and substantiated by test data.

An efficiency rated water softener is a DIR softener which also complies with specific performance specifications intended to minimize the amount of regenerant brine and water used in its operation. Efficiency rated water softeners shall have a rated salt efficiency of not less than 3350 grains of total hardness exchange per pound of salt (based on NaCl equivalency) (477 grams of total hardness exchange per kilogram of salt), and shall not deliver more salt than its listed rating. The efficiency is measured by a laboratory test described in NSF/ANSI 44. The test represents the maximum possible efficiency the system can achieve. Operational efficiency is the actual efficiency achieved after the system has been installed. It is typically less than the efficiency due to individual application factors including water hardness, water usage, and other contaminants that reduce the softener's capacity.

Refer to the Specifications, Familiarization and Warranty section of this Owner's Guide for more specific product information. To avoid contamination from improper handling and installation, your system should only be installed and serviced by your Culligan Man. Performance will vary based on local water conditions. The substances reduced by this system are not necessarily in your water.

Culligan water softeners are designed to work with any salt of good quality, although it is recommended that you ask your local Culligan Man for his suggestion on the best type and grade of salt to use in this softener.

**NOTICE** This softener is not intended to be used for treating water that is microbiologically unsafe or of unknown quality without adequate disinfection before or after the system.

†The efficiency rated dosage is only valid at the 3 lb. salt dosage and maximum service flow rate for 10" models.



## Performance Data Sheet

### Culligan High Efficiency 10" Upflow Water Softener with Aqua-Sensor® Sensing Device

Culligan knows the more informed you are about your water treatment systems, the more confident you will be about its performance. It's because of this and more than seventy years of commitment to customer satisfaction that Culligan is providing this Performance Data Sheet to its customers.

**NOTICE** Read this Performance Data Sheet and compare the capabilities of this unit with your actual water treatment needs. It is recommended that before purchasing a water treatment unit, you have your water supply tested to determine your actual water treatment needs.

Manufacturer: Culligan International Company  
9399 W. Higgins Rd., Suite 1100, Rosemont, IL 60018 USA  
(847) 430-2800



Product: Culligan High Efficiency 10" Upflow Water Softener with Aqua-Sensor® Sensing Device

#### Testing Conditions & Results:

Flow Rate:	9.4 gpm @ 12 psi	Capacity:	30,081 grains @ 6.0 lb. salt
Pressure:	30–40 psi (2.1–2.8 kg/cm <sup>2</sup> )		47,726 grains @ 12.0 lb. salt
Acidity:	Non-Corrosive		54,975 grains @ 18.0 lb. salt
Temperature:	68°F (20°C)	pH:	7.6
Efficiency Rated Dosage†:	5,014 gr/lb		

#### Softener Specifications:

Service Flow Rate: 9.4 gpm	Pressure Drop at Max. Flow Rate: 12 psi
Operating Temp. Range: 33–120°F (0–49°C)	Max. Drain Flow Rate: 2.3 gpm
Working Press. Range: 20–125 psi (1.4–8.5 kg/cm <sup>2</sup> )	Oper. Press. Range (Canada): 20–90 psi (1.4–6.3 kg/cm <sup>2</sup> )

Name of Substance	USEPA Max. Contaminant Level	pH	Flow Rate	Pressure
Barium	2.0 mg/L	7.5 + 0.5	9.4 gpm	12 (psig)
Radium 226/228	5 pCi/L	7.5 + 0.5	9.4 gpm	12 (psig)

This system is certified for barium and radium 226/228 reduction based on hardness reduction. It is recommended you test your water every six months to ensure the system is performing properly and that hardness, and therefore barium and radium 226/228, are being reduced. Hardness test strips have been included. Additional strips are available from your local Culligan dealer.

The Culligan High Efficiency 10" Upflow Water Softeners with Aqua-Sensor® Sensing Device are tested and certified by WQA against NSF/ANSI Standard 372, CSA B483.1, NSF/ANSI Standard 44 for the effective reduction of hardness (calcium and magnesium), barium, and radium 226/228, as verified and substantiated by test data.

An efficiency rated water softener is a DIR softener which also complies with specific performance specifications intended to minimize the amount of regenerant brine and water used in its operation. Efficiency rated water softeners shall have a rated salt efficiency of not less than 3350 grains of total hardness exchange per pound of salt (based on NaCl equivalency) (477 grams of total hardness exchange per kilogram of salt), and shall not deliver more salt than its listed rating. The efficiency is measured by a laboratory test described in NSF/ANSI 44. The test represents the maximum possible efficiency the system can achieve. Operational efficiency is the actual efficiency achieved after the system has been installed. It is typically less than the efficiency due to individual application factors including water hardness, water usage, and other contaminants that reduce the softener's capacity.

Refer to the Specifications, Familiarization and Warranty section of this Owner's Guide for more specific product information. To avoid contamination from improper handling and installation, your system should only be installed and serviced by your Culligan Man. Performance will vary based on local water conditions. The substances reduced by this system are not necessarily in your water.

Culligan water softeners are designed to work with any salt of good quality, although it is recommended that you ask your local Culligan Man for his suggestion on the best type and grade of salt to use in this softener.

**NOTICE** This softener is not intended to be used for treating water that is microbiologically unsafe or of unknown quality without adequate disinfection before or after the system.

†The efficiency rated dosage is only valid at the 3 lb. salt dosage and maximum service flow rate for 10" models.



## Performance Data Sheet

### Culligan High Efficiency Municipal 9" Water Softener

Culligan knows the more informed you are about your water treatment systems, the more confident you will be about its performance. It's because of this and more than seventy years of commitment to customer satisfaction that Culligan is providing this Performance Data Sheet to its customers.

**NOTICE** Read this Performance Data Sheet and compare the capabilities of this unit with your actual water treatment needs. It is recommended that before purchasing a water treatment unit, you have your water supply tested to determine your actual water treatment needs.

**Manufacturer:** Culligan International Company  
9399 W. Higgins Rd., Suite 1100, Rosemont, IL 60018 USA  
(847) 430-2800

**Product:** Culligan High Efficiency Municipal 9" Water Softener



#### Testing Conditions & Results:

Flow Rate:	9.0 gpm @ 11 psi	Capacity:	17,119 grains @ 4.0 lb. salt
Pressure:	30–40 psi (2.1–2.8 kg/cm <sup>2</sup> )		25,232 grains @ 8.0 lb. salt
Acidity:	Non-Corrosive		27,806 grains @ 12.0 lb. salt
Temperature:	68°F (20°C)	pH:	7.6
Efficiency Rated Dosage†:	4,280 gr/lb	Chlorine Taste and Odor Capacity:	300,000 gallons

#### Softener Specifications:

Service Flow Rate: 9.0 gpm	Pressure Drop at Max. Flow Rate: 12 psi
Operating Temp. Range: 33–120°F (0–49°C)	Max. Drain Flow Rate: 2.6 gpm
Working Press. Range: 20–125 psi (1.4–8.5 kg/cm <sup>2</sup> )	Oper. Press. Range (Canada): 20–90 psi (1.4–6.3 kg/cm <sup>2</sup> )

#### Substance Reduction

While testing was performed under standard laboratory conditions, actual performance may vary.

Substance	Influent Challenge Concentration	Reduction Requirement
Chlorine	2.0 mg/L ± 10%	≥50%
Particulate, Class V particles 30 to <50 µm	At least 1,000 particles/mL	≥85%

The Culligan HE Municipal 9" Water Softener is tested and certified by WQA against NSF/ANSI Standard 372, CSA B483.1, and NSF/ANSI Standard 44 for the effective reduction of hardness (calcium and magnesium), and NSF/ANSI Standard 42 for the effective reduction of Chlorine Taste and Odor, as verified and substantiated by test data.

An efficiency rated water softener is a DIR softener which also complies with specific performance specifications intended to minimize the amount of regenerant brine and water used in its operation. Efficiency rated water softeners shall have a rated salt efficiency of not less than 3350 grains of total hardness exchange per pound of salt (based on NaCl equivalency) (477 grams of total hardness exchange per kilogram of salt), and shall not deliver more salt than its listed rating. The efficiency is measured by a laboratory test described in NSF/ANSI 44. The test represents the maximum possible efficiency the system can achieve. Operational efficiency is the actual efficiency achieved after the system has been installed. It is typically less than the efficiency due to individual application factors including water hardness, water usage, and other contaminants that reduce the softener's capacity.

Refer to the Specifications, Familiarization and Warranty section of this Owner's Guide for more specific product information. To avoid contamination from improper handling and installation, your system should only be installed and serviced by your Culligan Man. Performance will vary based on local water conditions. The substances reduced by this system are not necessarily in your water.

Culligan water softeners are designed to work with any salt of good quality, although it is recommended that you ask your local Culligan Man for his suggestion on the best type and grade of salt to use in this softener.

**NOTICE** This softener is not intended to be used for treating water that is microbiologically unsafe or of unknown quality without adequate disinfection before or after the system.

†The efficiency rated dosage is valid only at the 4lb. salt dosage and 9.0 gpm flow rate for 9" models.





## Performance Data Sheet

### Culligan High Efficiency Municipal 10" Water Softener

Culligan knows the more informed you are about your water treatment systems, the more confident you will be about its performance. It's because of this and more than seventy years of commitment to customer satisfaction that Culligan is providing this Performance Data Sheet to its customers.

**NOTICE** Read this Performance Data Sheet and compare the capabilities of this unit with your actual water treatment needs. It is recommended that before purchasing a water treatment unit, you have your water supply tested to determine your actual water treatment needs.

**Manufacturer:** Culligan International Company  
9399 W. Higgins Rd., Suite 1100, Rosemont, IL 60018 USA  
(847) 430-2800



**Product:** Culligan High Efficiency Municipal 10" Water Softener

#### Testing Conditions & Results:

Flow Rate:	9.4 gpm @ 11 psi	Capacity:	21,399 grains @ 5.0 lb. salt
Pressure:	30–40 psi (2.1–2.8 kg/cm <sup>2</sup> )		31,540 grains @ 10.0 lb. salt
Acidity:	Non-Corrosive		34,758 grains @ 15.0 lb. salt
Temperature:	68°F (20°C)	pH:	7.6
Efficiency Rated Dosage†:	4,280 gr/lb	Chlorine Taste and Odor Capacity:	339,000 gallons

#### Softener Specifications:

Service Flow Rate: 9.4 gpm	Pressure Drop at Max. Flow Rate: 11 psi
Operating Temp. Range: 33–120°F (0–49°C)	Max. Drain Flow Rate: 2.6 gpm
Working Press. Range: 20–125 psi (1.4–8.5 kg/cm <sup>2</sup> )	Oper. Press. Range (Canada): 20–90 psi (1.4–6.3 kg/cm <sup>2</sup> )

#### Substance Reduction

While testing was performed under standard laboratory conditions, actual performance may vary.

Substance	Influent Challenge Concentration	Reduction Requirement
Chlorine	2.0 mg/L ±10%	≥50%
Particulate, Class V particles 30 to <50 µm	At least 1,000 particles/mL	≥85%

The Culligan HE Municipal 10" Water Softener is tested and certified by WQA against NSF/ANSI Standard 372, CSA B483.1, and NSF/ANSI Standard 44 for the effective reduction of hardness (calcium and magnesium), and NSF/ANSI Standard 42 for the effective reduction of Chlorine Taste and Odor, as verified and substantiated by test data.

An efficiency rated water softener is a DIR softener which also complies with specific performance specifications intended to minimize the amount of regenerant brine and water used in its operation. Efficiency rated water softeners shall have a rated salt efficiency of not less than 3350 grains of total hardness exchange per pound of salt (based on NaCl equivalency) (477 grams of total hardness exchange per kilogram of salt), and shall not deliver more salt than its listed rating. The efficiency is measured by a laboratory test described in NSF/ANSI 44. The test represents the maximum possible efficiency the system can achieve. Operational efficiency is the actual efficiency achieved after the system has been installed. It is typically less than the efficiency due to individual application factors including water hardness, water usage, and other contaminants that reduce the softener's capacity.

Refer to the Specifications, Familiarization and Warranty section of this Owner's Guide for more specific product information. To avoid contamination from improper handling and installation, your system should only be installed and serviced by your Culligan Man. Performance will vary based on local water conditions. The substances reduced by this system are not necessarily in your water.

Culligan water softeners are designed to work with any salt of good quality, although it is recommended that you ask your local Culligan Man for his suggestion on the best type and grade of salt to use in this softener.

**NOTICE** This softener is not intended to be used for treating water that is microbiologically unsafe or of unknown quality without adequate disinfection before or after the system.

†The efficiency rated dosage is valid only at the 5 lb. salt dosage and 9.4 gpm flow rate for 10" models.



## Performance Data Sheet

### Culligan High Efficiency Municipal 12" Water Softener

Culligan knows the more informed you are about your water treatment systems, the more confident you will be about its performance. It's because of this and more than seventy years of commitment to customer satisfaction that Culligan is providing this Performance Data Sheet to its customers.

**NOTICE** Read this Performance Data Sheet and compare the capabilities of this unit with your actual water treatment needs. It is recommended that before purchasing a water treatment unit, you have your water supply tested to determine your actual water treatment needs.

**Manufacturer:** Culligan International Company  
9399 W. Higgins Rd., Suite 1100, Rosemont, IL 60018 USA  
(847) 430-2800

**Product:** Culligan High Efficiency Municipal 12" Water Softener



C USA

#### Testing Conditions & Results:

Flow Rate:	10.0 gpm @ 11 psi	Capacity:	29,062 grains @ 7.0 lb. salt
Pressure:	30–40 psi (2.1–2.8 kg/cm <sup>2</sup> )		43,990 grains @ 18.0 lb. salt
Acidity:	Non-Corrosive		49,343 grains @ 30.0 lb. salt
Temperature:	68°F (20°C)	pH:	7.6
Efficiency Rated Dosage†:	4,152 gr/lb	Chlorine Taste and Odor Capacity:	621,000 gallons

#### Softener Specifications:

Service Flow Rate:	10.0 gpm	Pressure Drop at Max. Flow Rate:	11 psi
Operating Temp. Range:	33–120°F (0–49°C)	Max. Drain Flow Rate:	3.2 gpm
Working Press. Range:	20–125 psi (1.4–8.5 kg/cm <sup>2</sup> )	Oper. Press. Range (Canada):	20–90 psi (1.4–6.3 kg/cm <sup>2</sup> )

#### Substance Reduction

While testing was performed under standard laboratory conditions, actual performance may vary.

Substance	Influent Challenge Concentration	Reduction Requirement
Chlorine	2.0 mg/L ± 10%	≥50%
Particulate, Class V particles 30 to <50 µm	At least 1,000 particles/mL	≥85%

The Culligan HE Municipal 12" Water Softener is tested and certified by WQA against NSF/ANSI Standard 372, CSA B483.1, and NSF/ANSI Standard 44 for the effective reduction of hardness (calcium and magnesium), and NSF/ANSI Standard 42 for the effective reduction of Chlorine Taste and Odor, as verified and substantiated by test data.

An efficiency rated water softener is a DIR softener which also complies with specific performance specifications intended to minimize the amount of regenerant brine and water used in its operation. Efficiency rated water softeners shall have a rated salt efficiency of not less than 3350 grains of total hardness exchange per pound of salt (based on NaCl equivalency) (477 grams of total hardness exchange per kilogram of salt), and shall not deliver more salt than its listed rating. The efficiency is measured by a laboratory test described in NSF/ANSI 44. The test represents the maximum possible efficiency the system can achieve. Operational efficiency is the actual efficiency achieved after the system has been installed. It is typically less than the efficiency due to individual application factors including water hardness, water usage, and other contaminants that reduce the softener's capacity.

Refer to the Specifications, Familiarization and Warranty section of this Owner's Guide for more specific product information. To avoid contamination from improper handling and installation, your system should only be installed and serviced by your Culligan Man. Performance will vary based on local water conditions. The substances reduced by this system are not necessarily in your water.

Culligan water softeners are designed to work with any salt of good quality, although it is recommended that you ask your local Culligan Man for his suggestion on the best type and grade of salt to use in this softener.

**NOTICE** This softener is not intended to be used for treating water that is microbiologically unsafe or of unknown quality without adequate disinfection before or after the system.

†The efficiency rated dosage is valid only at the 7 lb. salt dosage and 10.0 gpm flow rate for 12" models.



## Performance Data Sheet

### Culligan High Efficiency Municipal 14" Water Softener

Culligan knows the more informed you are about your water treatment systems, the more confident you will be about its performance. It's because of this and more than seventy years of commitment to customer satisfaction that Culligan is providing this Performance Data Sheet to its customers.

**NOTICE** Read this Performance Data Sheet and compare the capabilities of this unit with your actual water treatment needs. It is recommended that before purchasing a water treatment unit, you have your water supply tested to determine your actual water treatment needs.

**Manufacturer:** Culligan International Company  
9399 W. Higgins Rd., Suite 1100, Rosemont, IL 60018 USA  
(847) 430-2800



**Product:** Culligan High Efficiency Municipal 14" Water Softener

#### Testing Conditions & Results:

Flow Rate:	10.6 gpm @ 11 psi	Capacity:	39,118 grains @ 9.0 lb. salt
Pressure:	30–40 psi (2.1–2.8 kg/cm <sup>2</sup> )		59,297 grains @ 18.0 lb. salt
Acidity:	Non-Corrosive		71,448 grains @ 28.0 lb. salt
Temperature:	68°F (20°C)	pH:	7.6
Efficiency Rated Dosage†:	4,346 gr/lb	Chlorine Taste and Odor Capacity:	935,000 gallons

#### Softener Specifications:

Service Flow Rate:	10.6 gpm	Pressure Drop at Max. Flow Rate:	11 psi
Operating Temp. Range:	33–120°F (0–49°C)	Max. Drain Flow Rate:	6.2 gpm
Working Press. Range:	20–125 psi (1.4–8.5 kg/cm <sup>2</sup> )	Oper. Press. Range (Canada):	20–90 psi (1.4–6.3 kg/cm <sup>2</sup> )

#### Substance Reduction

While testing was performed under standard laboratory conditions, actual performance may vary.

Substance	Influent Challenge Concentration	Reduction Requirement
Chlorine	2.0 mg/L ±10%	≥50%
Particulate, Class V particles 30 to <50 µm	At least 1,000 particles/mL	≥85%

The Culligan HE Municipal 14" Water Softener is tested and certified by WQA against NSF/ANSI Standard 372, CSA B483.1, and NSF/ANSI Standard 44 for the effective reduction of hardness (calcium and magnesium), and NSF/ANSI Standard 42 for the effective reduction of Chlorine Taste and Odor, as verified and substantiated by test data.

An efficiency rated water softener is a DIR softener which also complies with specific performance specifications intended to minimize the amount of regenerant brine and water used in its operation. Efficiency rated water softeners shall have a rated salt efficiency of not less than 3350 grains of total hardness exchange per pound of salt (based on NaCl equivalency) (477 grams of total hardness exchange per kilogram of salt), and shall not deliver more salt than its listed rating. The efficiency is measured by a laboratory test described in NSF/ANSI 44. The test represents the maximum possible efficiency the system can achieve. Operational efficiency is the actual efficiency achieved after the system has been installed. It is typically less than the efficiency due to individual application factors including water hardness, water usage, and other contaminants that reduce the softener's capacity.

Refer to the Specifications, Familiarization and Warranty section of this Owner's Guide for more specific product information. To avoid contamination from improper handling and installation, your system should only be installed and serviced by your Culligan Man. Performance will vary based on local water conditions. The substances reduced by this system are not necessarily in your water.

Culligan water softeners are designed to work with any salt of good quality, although it is recommended that you ask your local Culligan Man for his suggestion on the best type and grade of salt to use in this softener.

**NOTICE** This softener is not intended to be used for treating water that is microbiologically unsafe or of unknown quality without adequate disinfection before or after the system.

†The efficiency rated dosage is valid only at the 9 lb. salt dosage and 10.6 gpm flow rate for 14" models.



**California  
Department of  
Public Health  
Certificate**

**Culligan High  
Efficiency 9" Water  
Softener**

State of California  
Department of Public Health  
Water Treatment Device  
Certificate Number  
10-2044

Date Issued: August 2, 2010

**Trademark/Model Designation**

High Efficiency: 9" Aqua-Sensor  
9" Soft-Minder Meter  
Upflow 9" Soft-Minder Meter  
Upflow 9" Aqua-Sensor

**Replacement Elements**

**Manufacturer:** Culligan International

The water treatment device(s) listed on this certificate have met the testing requirements pursuant to Section 116830 of the Health and Safety Code for the following health related contaminants:

**Microbiological Contaminants and Turbidity**

**Organic Contaminants**

**Inorganic/Radiological Contaminants**

Barium  
Radium

**Rated Service Capacity:**

**Rated Service Flow:** 9 gpm

Do not use where water is microbiologically unsafe or with water of unknown quality, except that systems certified for cyst reduction may be used on disinfected waters that may contain filterable cysts.



State of California  
Department of Public Health  
Water Treatment Device  
Certificate Number  
10-2043

Date Issued: August 2, 2010

**California  
Department of  
Public Health  
Certificate**

**Culligan High  
Efficiency 10"  
Water Softener**

**Trademark/Model Designation**

**Replacement Elements**

High Efficiency: 10" Aqua-Sensor

10" Soft-Minder Meter

Upflow 10" Soft-Minder Meter

Upflow 10" Aqua-Sensor

**Manufacturer:** Culligan International

The water treatment device(s) listed on this certificate have met the testing requirements pursuant to Section 116830 of the Health and Safety Code for the following health related contaminants:

**Microbiological Contaminants and Turbidity**

**Inorganic/Radiological Contaminants**

**Organic Contaminants**

Barium  
Radium

**Rated Service Capacity:**

**Rated Service Flow:** 9.4 gpm

Do not use where water is microbiologically unsafe or with water of unknown quality, except that systems certified for cyst reduction may be used on disinfected waters that may contain filterable cysts.



**California  
Department of  
Public Health  
Certificate**

**Culligan High  
Efficiency 12"  
Water Softener**

State of California  
Department of Public Health  
Water Treatment Device  
Certificate Number  
10- 2046

Date Issued: August 2, 2010

**Trademark/Model Designation**

High Efficiency 12" Aqua-Sensor

High Efficiency 12" Soft-Minder Meter

**Manufacturer:** Culligan International

**Replacement Elements**

The water treatment device(s) listed on this certificate have met the testing requirements pursuant to Section 116830 of the Health and Safety Code for the following health related contaminants:

**Microbiological Contaminants and Turbidity**

**Organic Contaminants**

**Inorganic/Radiological Contaminants**

Barium  
Radium

**Rated Service Capacity:**

**Rated Service Flow:** 10 gpm

Do not use where water is microbiologically unsafe or with water of unknown quality, except that systems certified for cyst reduction may be used on disinfected waters that may contain filterable cysts.

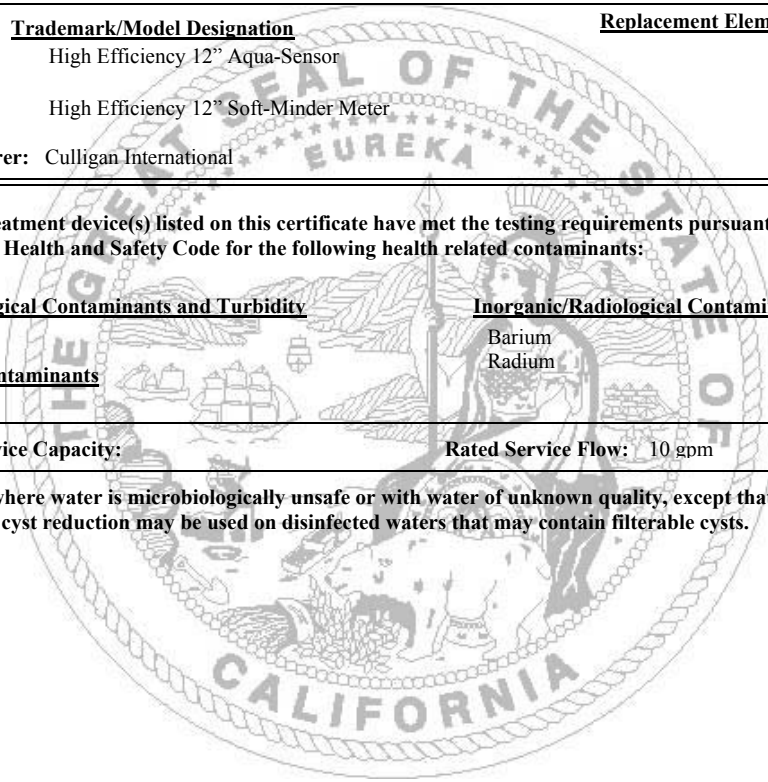



State of California  
Department of Public Health  
Water Treatment Device  
Certificate Number  
10 - 2045

Date Issued: August 2, 2010

**California  
Department of  
Public Health  
Certificate**

**Culligan High  
Efficiency 14"  
Water Softener**

Trademark/Model Designation

Replacement Elements

High Efficiency 14" Aqua-Sensor

High Efficiency 14" Soft-Minder Meter

Manufacturer: Culligan International

The water treatment device(s) listed on this certificate have met the testing requirements pursuant to Section 116830 of the Health and Safety Code for the following health related contaminants:

Microbiological Contaminants and Turbidity

Inorganic/Radiological Contaminants

Organic Contaminants

Barium  
Radium

Rated Service Capacity:

Rated Service Flow: 10.6 gpm

Do not use where water is microbiologically unsafe or with water of unknown quality, except that systems certified for cyst reduction may be used on disinfected waters that may contain filterable cysts.

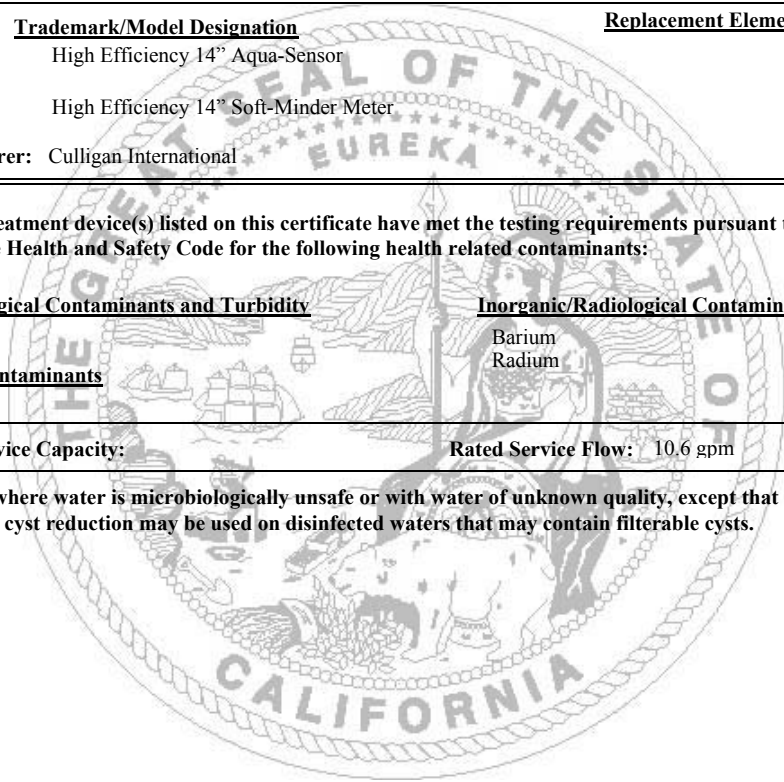



## Important Data on Your Water Softener

It is advisable to have the salesperson or installer fill in the information below for your future reference. If this has not been done, please ask for it, as it is necessary if you contact your dealer.

### Identification

Model Name \_\_\_\_\_ Catalog No. \_\_\_\_\_

Control Model No. \_\_\_\_\_ Control Serial No. \_\_\_\_\_

Date of Installation \_\_\_\_\_ Tank Serial No. \_\_\_\_\_

### Settings

Time of Recharge: \_\_\_\_\_ a.m. / \_\_\_\_\_ p.m.

Regeneration Interval \_\_\_\_\_ days

Number of people in household \_\_\_\_\_

Tank Size \_\_\_\_\_ inches

### Water Analysis

Total Hardness \_\_\_\_\_ (gpg)

Total Iron \_\_\_\_\_ (ppm)

pH (acidity) \_\_\_\_\_

Other \_\_\_\_\_

\_\_\_\_\_

\_\_\_\_\_

\_\_\_\_\_







## Parts List

### High Efficiency Control Valve Assembly (Indoor/Outdoor)

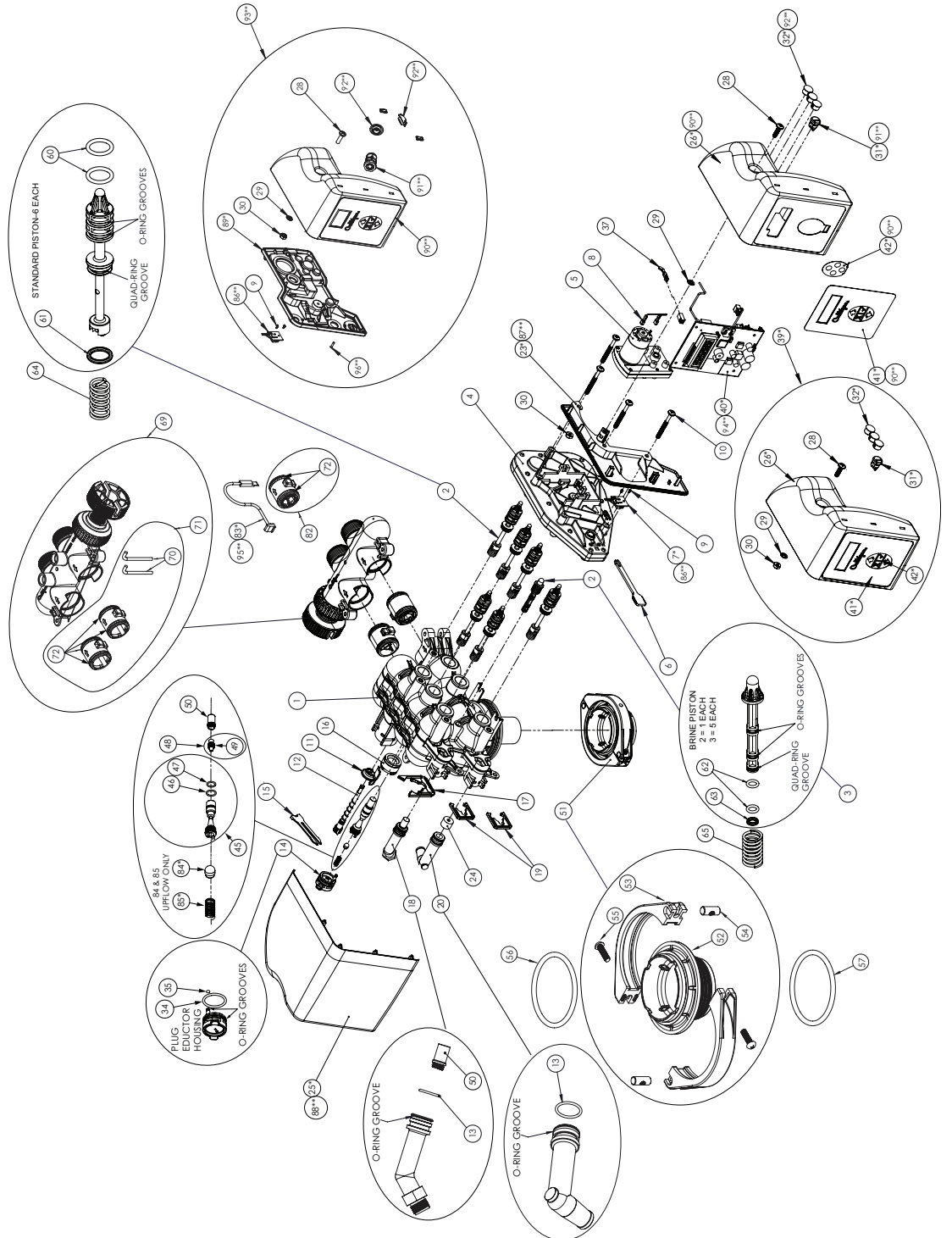

Item	Part Number	Description
*	01023111	HE Indoor Control Valve, Dowflow, Complete
*	01023115	HE Indoor Control Valve, Upflow, Complete
1	01023020	Valve Body
2	01025267	Piston Rebuild Kit, Includes 6ea Standard Piston assemblies and 1ea Brine Piston Assembly
3	P1022786	Brine Piston w/80 Duro Quad Seal, HE 1", 5ea
4	01020440	Gear Box Assembly, Downflow
	01022234	Gear Box Assembly, Upflow
5	01020240	Gearmotor
6	P1020415	Retainer, Gearmotor, 10ea
7*	01020420	Wire Harness w/ Position Sensor, Indoor
8	01022735	Wire Harness, Motor
9	P1020433	Position Sensor Screw, 10ea
10	P1020517	Gear Box Assembly Screw, 10ea
11	P1020289	Dial-a-Softness Knob, 10ea
12	P1020427	Dial-a-Softness Assembly w/ O-Rings, 10ea
13	P0440268	O-Ring, Brine & Drain Elbow, 10ea/Kit
14	P1020487	Eductor Plug Assembly w/ O-Rings, 10ea
15	P1020290	Eductor Plug Retainer, 10ea
16	P1023051	Dial-a-Softness Locking Plug, 10ea
17	P1020291	Dial-a-Softness Locking Plug Retainer, 10ea
18	P1020581	Brine Elbow Assembly, 10ea
19	P1020432	Retainer, Brine & Drain Elbow, 10ea
20	P1023021	Drain Elbow Assembly, 10ea
23*	01023014	Enclosure Frame, Indoor
24	P0331635	Backwash Flow Control, #2 Brown, 10ea
	P0331636	Backwash Flow Control, #3 Green, 10ea
	P0401031	Backwash Flow Control, Black, 10ea
25*	01023066	Cover, Hood, Compact, HE Control, Indoor
26*	—	Hood, Compact, HE Control, Indoor (not available for sale), Kit
28	P0318383	Enclosure Screw, 10ea/Kit
29	P1023122	Retainer for Enclosure Screw, 10ea/Kit
30	P1020617	Nut for Enclosure Screw, 10ea/Kit
31*	P1000372	Strain Relief Fitting, Indoor 25ea/Kit
32*	P1006498	Plug, Indoor 10ea/Kit
34	P1021162	O-ring, Eductor Plug Assembly, Large, 10ea/Kit
35	P1020424	O-ring, Eductor Plug Assembly, Small, 10ea/Kit
37	01017134	Power Cord
39*	01023448	Electronics Enclosure Kit less Circuit Board, Indoor
40*	01023447	Replacement Circuit Board, Indoor
41*	P1023112	Circuit Board Label, Indoor, 10ea/Kit
42*	P1020497	Keypad with Connector, indoor 10ea/Kit
45	P1022796	Eductor Throat with O-rings, Downflow, Tan, 10ea
	P1022723	Eductor Throat with O-rings, Downflow, Blue, 10ea
	P1023712	Eductor Throat with O-rings, Upflow, Gray, 10ea
	P1023713	Eductor Throat with O-rings, Upflow, White, 10ea
46	P1020603	Eductor Throat O-ring, Large, 10ea/Kit
47	P1020428	Eductor Throat O-ring, Small, 10ea/Kit
48	P1013894	Eductor Nozzle w/ O-ring, Blue, 10ea
	P1013895	Eductor Nozzle w/ O-ring, Beige, 10ea
	P1024333	Eductor Nozzle w/ O-ring, Green, 10ea
49	P0308438	O-ring, Eductor Nozzle, 10ea/Kit
50	P1020256	Screen, 10ea/Kit
51	01014153	Tank Adapter Assy, 1" valve to tank less O-Rings
52	01013958	Tank Adapter, 1" Valve, Kit
53	P1013959	Tank Clamp, 1" Valve, Kit

Item	Part Number	Description
54	P1013669	Tank Clamp Pin, 1" Valve, 10ea/Kit
55	P0318383	Tank Clamp Screw, 1" Valve/3/4" bkt, 10ea/Kit
56	P1014848	O-ring, Large, Valve to Tank Adapter, 25ea
57	P0440052	O-ring, Valve Adapter to ACME Tank, 25ea
60	P1020431	Main Piston O-ring, 25ea/Kit
61	P1025199	Main Piston Quad Ring, 25ea/Kit
62	P1020426	Brine Piston O-ring 25ea/Kit
63	—	Brine Piston Quad Ring (not available for sale), Kit
64	P1020252	Main Piston Spring, 10ea
65	P1020286	Brine Piston Spring 10ea
69	01018760	Bypass Valve, Rotary
70	P1009075	Retaining Clip, 1" Bypass valve, 10ea/Kit
71	01014033	Coupling Kit - 1" Bypass
72	P1009099	O-ring, Couplings/Meters, 50ea/Kit
82	01026849	Meter Kit Assembly, HE 1", LF
83*	01023117	Wire Harness, Meter, 28"Long, Indoor
84	P1023699	Half Ball w/ Post, Upflow Only, 10ea (only upflow models)
85	P1023695	Spring, Upflow Only, 10ea (only upflow models)
***	P0451701	Hose Clamp, Drain, 25ea
***	01018249	1 1/4" Straight Through Adapter
***	01018755	Rebuild Kit - 1"/1 1/4" Rotary Bypass
***	P1016467	Replacement O-Ring for Bypass Valve Stem, 50ea/Kit
***	01010783	1" Copper Adapter Kit, (1" Bypass)
***	01016564	3/4" Copper Adapter Kit (1" Bypass)
***	01016565	3/4" Elbow Copper Adapter Kit (1" Bypass)
***	P1018757	1" NPT Female Elbow Kit (1" Rotary Bypass), 10ea
***	P1009856	Gasket, Copper Plumbing Adapters, 25ea
***	01018133	Transformer, Dual Output
***	01020620	Transformer, Dual Output w/ 6' Power Cord (optional)
***	01020748	Auxiliary Board (optional)
<b>Outdoor Part Numbers</b>		
**	01025717	HE Outdoor Control Valve, Downflow, Complete
**	01025718	HE Outdoor Control Valve, Upflow, Complete
86**	—	Wire Harness w/Position Sensor, Outdoor (not available for sale), Kit
87**	01024917	Frame, Hood Compact, HE Control, Outdoor
88**	01024946	HE 1" Control Valve Cover, Outdoor
89**	—	Compartment Plate w/Gaskets, Outdoor (not available for sale), Kit
90**	—	Enclosure w/Decal and Keyboard, Outdoor (not available for sale), Kit
91**	P1025274	Strain Relief Fitting, Outdoor, 10ea/Kit
92**	P1025277	Liquid Tight Hole Plug, Outdoor, 10ea/Kit
93**	01025650	Electronics Enclosure Kit less Circuit Board, Outdoor
94**	01020745	Replacement Circuit Board, Outdoor
95**	01025282	Wire Harness, Meter, 28" Long, Outdoor
96**	P1023200	Compartment Plate Screw, Outdoor, 10ea/Kit
**	01025561	Outdoor Transformer, Dual Output w/6' Power Cord (optional)
**	P1025264	Strain Relief Fitting, Outdoor, 10ea

\*Indoor ONLY Part Number

\*\*Outdoor ONLY Part Number

\*\*\* Not shown





## Parts List

### Remote Display and Accessories

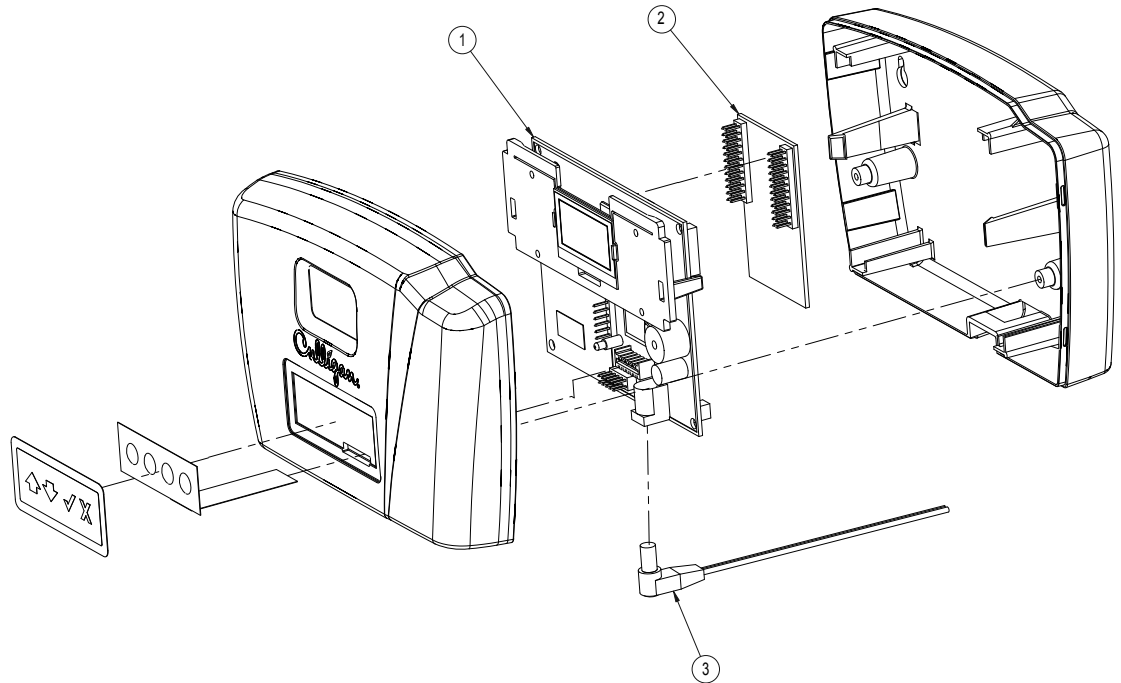

Item	Part No.	Description
	01020553	Remote Display Assembly, Softener/Filter - 915 MHz, North American English Version
	D1025235	Remote Display Assembly, Softener/Filter - 869 MHz, European English Version
	D1020608	Remote Display Assembly, Softener/Filter - 869 MHz, European French Version
	D1025110	Remote Display Assembly, Softener/Filter - 869 MHz, European Italian Version
	D1025111	Remote Display Assembly, Softener/Filter - 869 MHz, European Spanish Version
1	01020749	Circuit Board, Remote Soft/Filt, English Replacement
1	01024866	Circuit Board, Remote Soft/Filt, French Replacement
1	01025113	Circuit Board, Remote Soft/Filt, Italian Replacement
1	01025114	Circuit Board, Remote Soft/Filt, Spanish Replacement
2	01020750	Circuit Board, RF, GBE, 915 MHz, North American Version
2	01020751	Circuit Board, RF, GBE, 869 MHz, European Version
3	01020611	Transformer, North American Version
3	01025146	Transformer, EU Version
Accessories		
	01020747	Modem Circuit Board
	01022238	Alarm Relay Board
	01026885	SBT Sensor w/Chamber, HE Indoor
	01027289	SBT Sensor w/Chamber, HE Outdoor
	01018763	Aqua-Sensor, Hanging, HH, Indoor
	01025283	Aqua-Sensor, Hanging HE 1/1.25, Outdoor

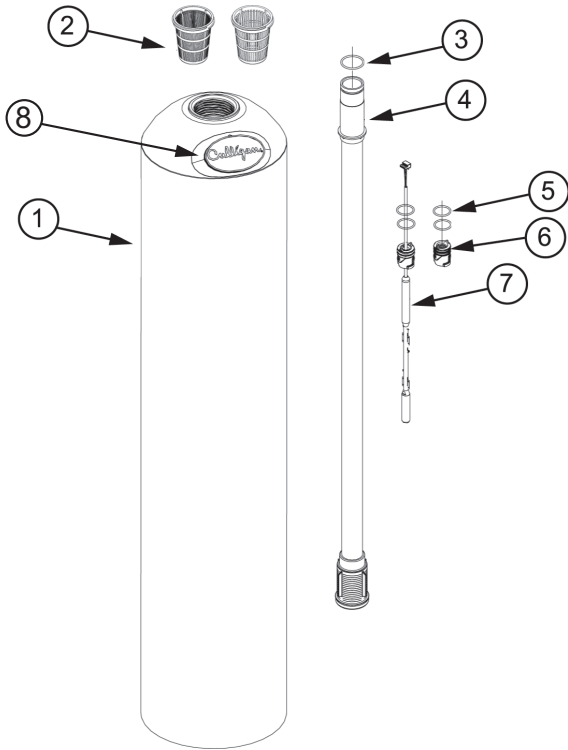

Item	Part No.	Description	Qty
1	01016617	Tank Assembly, 9" w/ Fillport, Complete	
	01016618	Tank Assembly, 10" w/ Fillport, Complete	
	01017192	Tank Assembly, 12" w/ Fillport, Complete, Less Media	
	01017194	Tank Assembly, 14" w/ Fillport, Complete, Less Media	
	01016351	Tank Assembly, 9" w/o Fillport, Complete	
	01016352	Tank Assembly, 10" w/o Fillport, Complete	
	01016349	Tank Replacement, 9", w/ Fillport, Empty	
	01016350	Tank Replacement, 10", w/ Fillport, Empty	
	01016347	Tank Replacement, 9", w/o Fillport, Empty	
	01016348	Tank Replacement, 10", w/o Fillport, Empty	
2	P1009847	Top Strainer - Fine Slot, 10ea	
	P1011195	Top Strainer - Wide Slot, 10 ea	1
3	P1009099	O-Ring, Manifold, 50ea	1
4	01016176	Outlet Manifold - 9"	1
4	01014539	Outlet Manifold - 10"	1
4	01018846	Outlet Manifold - 12"	1
4	01016429	Outlet Manifold - 14"	1
5	P1017434	O-Ring, Plug and Sensor, 10ea	2
6	01015122	Plug	1
7	01018763	Aqua-Sensor® Probe, Indoor	1
7	01025283	Aqua-Sensor® Probe, Outdoor	1
8	01016174	Culligan Emblem	1
—	00156001	Cullex, 1 Cubic Foot	*
—	00160702	Cullsan, 20 lb bag	*

\*Refer to "Specifications" on page 2 for the amount of Cullex and Cullsan needed for the unit's tank.

Part No.	Description	Media Quantity		
		Cullex	Carbon	Cullsan
01019848	Culligan HE Municipal Media Replacement Kit for 9" Tanks (2 boxes)	0.8 ft3	6 lbs	12 lbs
01019849	Culligan HE Municipal Media Replacement Kit for 10" Tanks (2 boxes)	1.0 ft3	8 lbs	15 lbs
01019850	Culligan HE Municipal Media Replacement Kit for 12" Tanks (2 boxes)	1.5 ft3	12 lbs	20 lbs
01019851	Culligan HE Municipal Media Replacement Kit for 14" Tanks (3 boxes)	2.3 ft3	18 lbs	25 lbs

## Parts List

### Tank Assembly

## High Efficiency Municipal Replacement Media Packs

(Includes, underbedding, Cullex, and Carbon)



## Parts List

### 16" and 18" Brine System

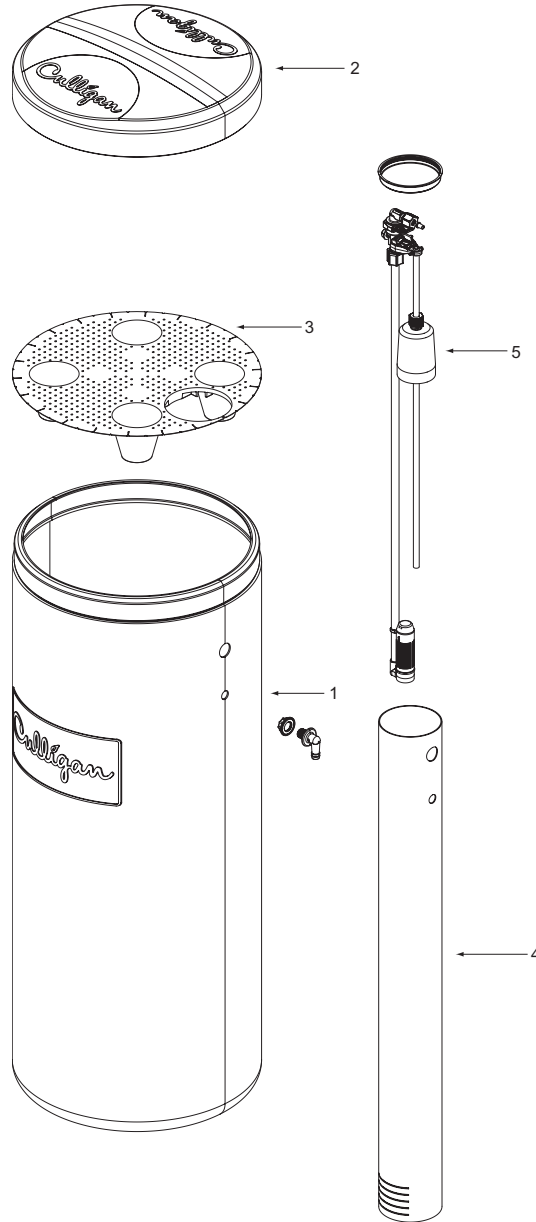

Item	Part No.	Description
-	01018705	Brine System, 250 lb
-	01018715	Brine System, 375 lb
1	01018709	Replacement Tank, 250 lb
	01018716	Replacement Tank, 375 lb
2	-	Cover, 250 lb (not available for sale)
	01018717	Cover, 375 lb
3	01018707	Salt Plate, 250 lb
	01018713	Salt Plate, 375 lb
4	01018708	Brine Chamber, 250 lb & 375 lb
5	01018706	Brine Valve



## Parts List

### Brine Valve Assembly

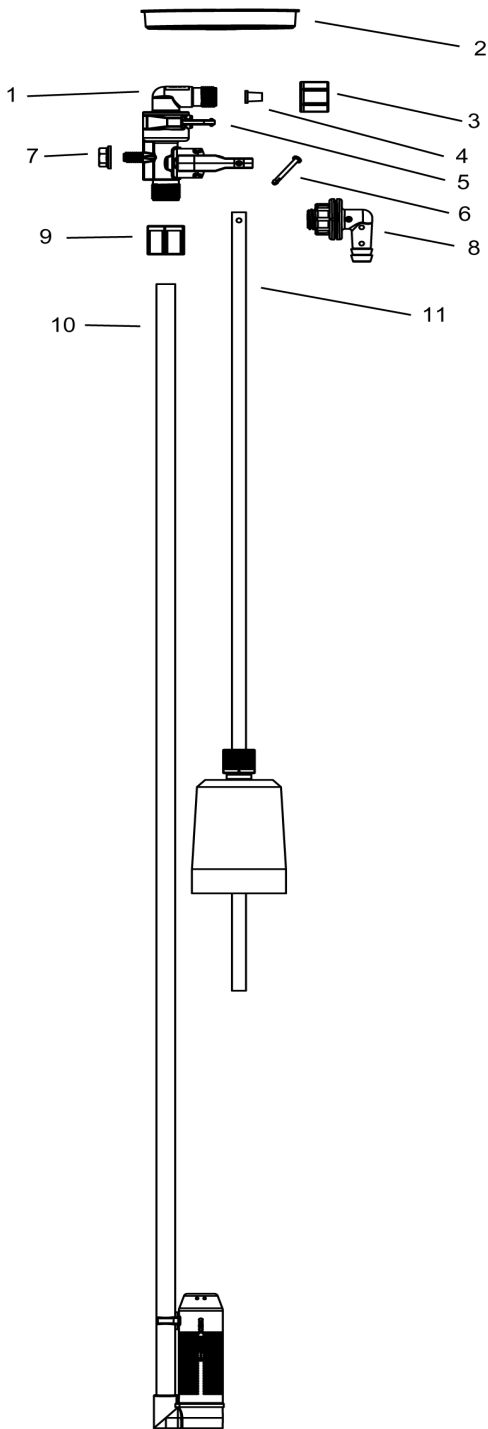

Item	Part No.	Description
-	01018706	Brine Valve
1	01018710	BLFC Elbow - 0.45 gpm
	01018711	BLFC Elbow - 0.8 gpm
2	P1020194	Brine Well Cap - 24 Pack
3	P1020196	3/8" Compression Nut - 24 Pack
4	P1018871	3/8" Insert - 25 Pack
5	P1020191	Retaining Clip - 24 Pack
6	P1020192	Pin - 24 Pack
7	P1020193	5/16" Nut - 24 Pack
8	P1020190	Overflow Fitting w/ Nut - 24 Pack
9	P1020195	3/8" Nut - 24 Pack
10	P1020198	Air check Assembly - 24 Pack
11	P1020197	Float - 24 Pack



## Parts List

### 24" Brine System

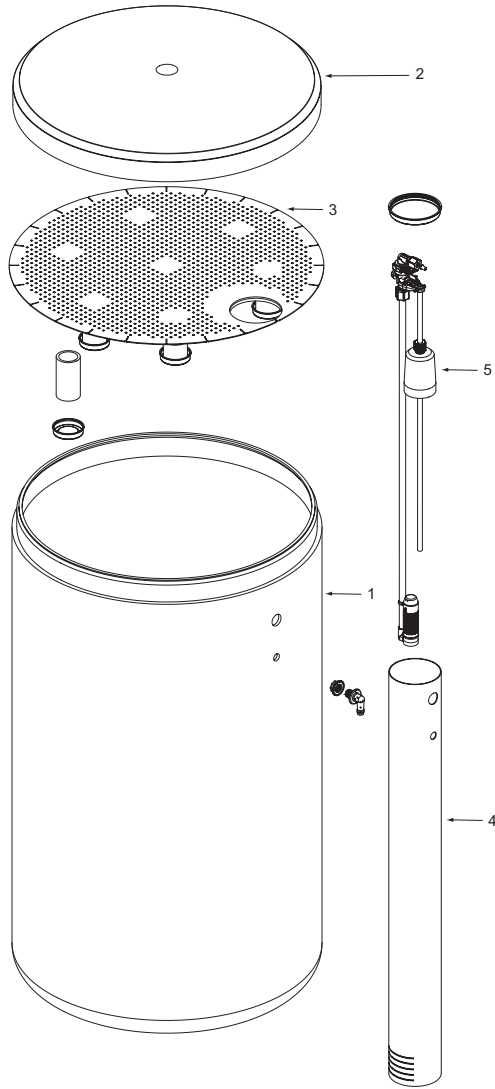

Item	Part No.	Description
-	01018720	Brine System, 650 lb
1	01018718	Replacement Tank, 650 lb
2	01018719	Cover, 650 lb
3	01018714	Salt Plate, 650 lb
4	01018708	Brine Chamber
5	01018706	Brine Valve





## Culligan Limited Warranty

### Culligan High Efficiency Automatic Water Conditioners

You have just purchased one of the finest water conditioners made. As an expression of our confidence in Culligan International Company products, your water conditioner is warranted to the original end-user, when installed in accordance with Culligan specifications, against defects in material and workmanship from the date of original installation, as follows:

<b>For a period of ONE YEAR</b>	The entire conditioner and Culligan HE Municipal Media
<b>For a period of FIVE YEARS</b>	Remote display, modem, Soft-Minder® meter, Smart Brine probe, or Aqua-Sensor® probe, if so equipped.
<b>For a period of TEN YEARS</b>	High Efficiency circuit board, control valve body, excluding internal parts. The salt storage container, brine valve and all its component parts
<b>For the LIFETIME of the original consumer purchaser</b>	The Quadra-Hull™ conditioner tank and the Cullex® resin

If a part described above is found defective within the specified period, you should notify your independently operated Culligan dealer and arrange a time during normal business hours for the dealer to inspect the water conditioner on your premises. Any part found defective within the terms of this warranty will be repaired or replaced by the dealer. You pay only freight from our factory and local dealer charges.

We are not responsible for damage caused by accident, fire, flood, freezing, Act of God, misuse, misapplication, neglect, oxidizing agents (such as chlorine, ozone, chloramines and other related components), alteration, installation or operation contrary to our printed instructions, or by the use of accessories or components which do not meet Culligan specifications, is not covered by this warranty. Refer to the specifications section in the Installation and Operating manual for application parameters.

Our product performance specifications are furnished with each water conditioning unit. TO THE EXTENT PERMITTED BY LAW, CULLIGAN DISCLAIMS ALL IMPLIED WARRANTIES, INCLUDING WITHOUT LIMITATION WARRANTIES OF MERCHANTABILITY AND FITNESS FOR PARTICULAR PURPOSE; TO THE EXTENT REQUIRED BY LAW, ANY SUCH IMPLIED WARRANTIES ARE LIMITED IN DURATION TO THE ONE-YEAR PERIOD SPECIFIED ABOVE FOR THE ENTIRE CONDITIONER. As a manufacturer, we do not know the characteristics of your water supply or the purpose for which you are purchasing a water conditioner. The quality of water supplies may vary seasonally or over a period of time, and your water usage rate may vary as well. Water characteristics can also differ considerably if your water conditioner is moved to a new location. For these reasons, we assume no liability for the determination of the proper equipment necessary to meet your requirements, and we do not authorize others to assume such obligations for us. Further, we assume no liability and extend no warranties, express or implied, for the use of this product with a non-potable water source. OUR OBLIGATIONS UNDER THIS WARRANTY ARE LIMITED TO THE REPAIR OR REPLACEMENT OF THE FAILED PARTS OF THE WATER CONDITIONER, AND WE ASSUME NO LIABILITY WHATSOEVER FOR DIRECT, INDIRECT, INCIDENTAL, CONSEQUENTIAL, SPECIAL, GENERAL, OR OTHER DAMAGES.

Some states do not allow the exclusion of implied warranties or limitations on how long an implied warranty lasts, so the above limitation may not apply to you. Similarly, some states do not allow the exclusion of incidental or consequential damages, so the above limitation or exclusion may not apply to you. This warranty gives you specific legal rights, and you may also have other rights which vary from state to state. Consult your telephone directory for your local independently operated Culligan dealer, or write Culligan International Company for warranty and service information.

#### Culligan International Company

9399 W. Higgins Road, Suite 1100  
Rosemont, Illinois 60018  
[www.culligan.com](http://www.culligan.com)



## **With Culligan You Get More Than A Quality Product**

### **You Get Your Water Expert, The Culligan Man**

We're here to provide you with fast, dependable service, making sure any problems you have are taken care of. The Culligan Man has been around for over seventy years, delivering quality products and dependable service all along. That's why people say "Hey, Culligan Man!®" Because we're the water experts. And that's who you want taking care of your water.

### **The Culligan Promise**

At Culligan, we understand that a water quality improvement system is an investment in your family's well-being. That's why our 1,350 independently operated dealers worldwide don't just sell products; they sell water quality you can count on. We stand behind our products with written limited warranties and our unequalled Culligan service. No matter where you live, you can depend on Culligan expertise to work for you—today and tomorrow.



## Index

### A

Accessories [72](#)  
Application [11](#)  
Aqua Salt Err [45](#)  
Aqua-Sensor® [2, 8, 14, 39](#)  
Aqua Sens Probe [45](#)  
Auxiliary Alarm [45](#)

### B

Backwash Flow Control [16, 17](#)  
Bacterial Iron [6](#)  
Blown Fuse [44](#)  
Brine Blocked [45](#)  
Brine Line [21](#)  
Brine Overflow [45](#)  
Brine Refill [7](#)  
Brine System [7, 74, 76](#)  
Brine Valve "A" Dimension [22](#)  
Brine Valve Assembly [75](#)  
button [27](#)  
Bypass [47](#)  
Bypass Valve [20, 44, 47](#)

### C

cable lengths, HE [14](#)  
California Department of Public Health Certificate  
[64, 65, 66, 67](#)  
Call Culligan at [45](#)  
Call for Service [44](#)  
CANCEL button [27](#)  
Care [41](#)  
Check Brine Tank [45](#)  
CHECK MARK button [27](#)  
Check SBT Sensor [45](#)  
Circuit Board Connections [22](#)  
Cleaning [41, 42](#)  
Control Valve [7, 10, 15, 70](#)  
Cover, Attaching the [18](#)  
Cullex resin [7](#)  
Cullsan® underbedding [7](#)

### D

Data [68](#)  
Date and Time, Set [32](#)  
Delayed Regeneration [36](#)  
Dial-A-Softness® [9, 19](#)  
Dissolved Iron [6](#)  
DOWN ARROW button [27](#)  
Downflow Regeneration [2, 9](#)  
Drain Facilities [12](#)  
Drain Line Connection [21](#)  
Dubl-Safe™ valve [7](#)

### E

Eductor Nozzle and Throat [16](#)

Electrical Facilities [12](#)  
Electrical Schematic [69](#)  
Error Codes [45](#)

### F

First Time Setup [29](#)  
Floor Surface [11](#)  
Flow Restrictors [16](#)

### H

Height of Discharge Above Floor Level Operating  
[21](#)

### I

Immediate Regeneration [36](#)  
Increased Usage [44](#)  
Information [34](#)  
Installation [10](#)  
Introduction [5](#)  
Iron [6](#)

### K

Keypad [27](#)

### L

Location [11](#)  
Low Battery [46](#)  
Low Salt Level [46](#)

### M

Maintenance, Preventative [41](#)  
Manual Regeneration [8, 37](#)  
Materials [10, 11](#)  
Media Packs [73](#)  
Media Tank [10](#)  
Menus, Navigating the [27](#)  
Meter [2, 8, 38](#)  
Mineral Tank [7, 13](#)  
Modem [8](#)  
Motor Home Err [46](#)  
Motor Position Error [46](#)  
Municipal [4, 73](#)

### N

No Refill [46](#)  
No Remote Signal [46](#)  
No Water [44](#)

### O

Operation [8](#)  
Organic Bound Iron [6](#)

### P

Particulate Iron [6](#)  
Parts List [70](#)



Performance Data Sheet [48, 49, 50, 51, 52, 53, 54, 55, 56, 57, 58, 59, 60, 61, 62, 63](#)

Placement [12](#)

Plumbing Connections [19](#)

Pos Sensor Err [46](#)

Power Failure [44](#)

Power Supply [44](#)

Predict Mode [8](#)

Pre-Rinse Mode [8](#)

Pressure [11](#)

Proportional Brining [9](#)

## **R**

Regeneration [7, 36, 37](#)

Remote [8, 72](#)

Replace Ext Filt [46](#)

Restrictors, Flow [16](#)

## **S**

Salt Bridging [46](#)

Salt Delivery Service [40](#)

Salt Economizer [40](#)

Salt Storage [10, 22, 42](#)

Salt Supply [40](#)

Sanitizing Procedure [43](#)

Service [7](#)

Smart Brine Tank Probe [8](#)

Space Requirements [11](#)

Specifications [2](#)

Startup, Final [38](#)

## **T**

Tank Assembly [12, 73](#)

Tank, Load the [13](#)

Temperature [11](#)

Time, Set Date and [32](#)

Tools [10](#)

## **U**

UP ARROW button [27](#)

Upflow Regeneration [3, 9](#)

## **W**

Warranty [77](#)

Water Quality [11](#)

Wireless Remote [8](#)



## Notes

